



JCI-C Heritage

2012 Survey Report on International Cooperation
Japan Consortium for International Cooperation
in Cultural Heritage

Survey Report on the Protection of Cultural Heritage in Republic of the Philippines



2012 Survey Report on International Cooperation
Japan Consortium for International Cooperation in Cultural Heritage

Survey Report on the Protection of Cultural Heritage in Republic of the Philippines

2012 Survey Report on International Cooperation
Japan Consortium for International Cooperation in Cultural Heritage
Survey Report on the Protection of Cultural Heritage
in Republic of the Philippines
July 2014

Published by
Japan Consortium for International Cooperation in Cultural Heritage
13-43 Ueno Park, Taito-ku, Tokyo, 110-8713 JAPAN
Tel:+81-3-3823-4841 Fax: +81-3-3823-4027
URL: <http://www.jcic-heritage.jp/>

Preface

Examination of Support for Protection of Cultural Heritage in the Multiethnic Country of the Philippines

Open any guidebook for the Philippines, and you will find pages of information on marine leisure activities, marine sports and resort accommodations, but only a few on the locations and descriptions of cultural heritage. Throughout the country, however, there are many cultural heritage sites that are yet unknown in Japan. Today, there are three World Cultural Heritage sites and three World Natural Heritage sites in the Philippines. They include churches in reflection of the history of one of the few countries in Asia where Christians, especially Catholics comprise the majority among other religious groups.

To acquire an understanding of the state of little known cultural heritage and activities for its protection, the Japan Consortium for International Cooperation in Cultural Heritage conducted a study on international cooperation in cultural heritage in the Philippines in February 2013.

As a multiethnic nation, the Philippines is home to diverse cultural heritage, as is also shown by the extensive collection of ethnic exhibits in museums. The numerous islands of the Philippines were placed under colonial rule before they were unified as a state and emerged as the Republic of the Philippines after World War II. Citizens of any modern nation seek their own national identity. This is normally achieved by sharing a common history, and since cultural heritage sites are manifestations of history, they are important assets shared by the people.

A number of sites in the Philippines, including prehistoric ruins and churches on Cebu Island, are on the Tentative List of World Heritage Sites. This fact is an indication that the country is a multiethnic nation that has numerous and diverse examples of cultural heritage.

However, recognition of cultural heritage is still very low in the Philippines, and there are many obstacles to the restoration of cultural heritage from the perspective of inheriting it through generations. A particularly large issue is the shortage of human resources to protect cultural heritage, owing in part to the lack of human resource development and training institutions. The situation relating to cultural heritage in the Philippines and its protection is thus rife with issues.

Large expectations are placed on Japan's cooperation in identifying the large numbers of Hizen porcelain artifacts that have been unearthed throughout the country, and in researching and preserving them from the perspective of Southeast Asia as a whole. The porcelain reflects the long history of trade in the region, and also includes pieces made in China and Vietnam. As their distinction could be identified with knowledge and experience, Japan's wealth of studies and know-how in this field could benefit the Philippines.

Many of the churches that are registered on the World Heritage List are made of brick walls and a wooden roof with roofing tiles. Buildings that line the historic town of Vigan also display a brick lower structure and wooden upper structure. Such large numbers of wooden buildings and buildings with roofing tiles in the Philippines could perhaps be brought under the scope of Japan's cooperation in cultural property protection in the future.

The Philippines became a battleground to Japan during World War II. Thus in a sense, Japan could be said to have a responsibility to make efforts to mitigate any of the negative legacies it had left in the country from those times.

It seems international cooperation in cultural heritage protection activities is still scarce in the Philippines, although countries such as Spain, Germany, France, the United States and Japan are respectively providing cooperation in their strong fields. Nevertheless, compared to the wide-ranging international cooperation implemented in other countries in southeast Asia, there are probably many more issues to address in the Philippines.

The year 2013 marked the 40th anniversary of the relationship between ASEAN and Japan. Progress in cooperation between the Philippines and Japan for the protection of such cultural heritage as porcelain artifacts and wooden buildings might perhaps also contribute to cultural property protection policies in all of Southeast Asia.

July 2014

Kunikazu Ueno

Chairman, Subcommittee for Southeast Asia

Japan Consortium for International Cooperation in Cultural Heritage

Foreword

1. This document is a report on a country assistance study conducted in the Philippines to assess the state of cultural heritage protection in the country. It has been published as a project of the Japan Consortium for International Cooperation in Cultural Heritage sponsored by the Agency for Cultural Affairs.

2. This report has been written and edited by the following members.

Written by:

1. Introduction

(Pages 7-9) Kazuhiko Tanaka (Lecturer, Institute of Asian Cultures, Sophia University)

(Page 9-10) Juan Ramon Jimenez Verdejo (Associate Professor, Department of Design and Architecture, School of Environmental Science, The University of Shiga Prefecture)

2. Study Overview

Rei Harada (Research Fellow, Japan Consortium for International Cooperation in Cultural Heritage)

3. Framework for Cultural Heritage Protection in the Philippines

Rei Harada

4. Cultural Heritage Sites in the Philippines

(Pages 23-25) Rei Harada

(Pages 26-35, 42-43, 48-49,) Kazuhiko Tanaka

(Pages 36-41, 44-47, 50-67) Juan Ramon Jimenez Verdejo

5. Observations

Rei Harada, Kazuhiko Tanaka, Kunikazu Ueno, Juan Ramon Jimenez Verdejo

Appendix

Rei Harada

Edited by: Rei Harada

3. The English and Spanish names of archaeological sites and buildings are based on what were judged as typically-used names found in publications and other reference materials. When building names are a combination of English and Spanish, local usage has been adopted. For this reason, some names in this report may differ from the names under which sites and heritage have been registered as World Heritage.

4. After the research, an earthquake struck the Cebu and Bohol islands in October, 2013. Cultural sites this research targeted have been affected by the disaster. Thus, when commenting on the present status of the cultural sites, it was considered important to include descriptions of the extent of damage as much as possible. Therefore, Chapter 4, "Cultural heritage in the Philippines," includes descriptions of the extent of damage to the sites following the October 2013 earthquake that struck Cebu and Bohol Islands, based on a local survey by Juan Ramon Jimenez Verdejo as reported in his "Earthquake Research Survey on Bohol Island (Challenging Exploratory Research / general research fund)."

Contents

Preface	3
Foreword	4
1. Introduction	7
1-1. The Philippines	7
1-2. Archaeological heritage in the Philippines	8
1-3. Historic Buildings in the Philippines	9
2. Study Overview	11
2-1. Objective	11
2-2. Implementation Period	11
2-3. Study Team Members	11
2-4. Content of the Study	11
2-5. Background to the Study	11
2-6. Study Method	12
2-7. Interviews	12
2-8. Activity Record	14
2-9. Reason for Selecting the Philippines for the Study	14
3. Framework for Cultural Heritage Protection in the Philippines	17
3-1. National Overview	17
3-2. Laws Concerning Cultural Heritage	17
3-3. Administration	21
4. Cultural Heritage Sites in the Philippines	23
4-1. Northern Luzon (Cagayan area)	26
4-2. Northern Luzon (Vigan area)	36
4-3. Central Luzon (Manila and Angono)	40
4-4. Cebu	50
4-5. Bohol	62
5. Observations	69
5-1. Present State and Issues	69
5-2. Possibilities for Future Cooperation and Japan's Role	71
5-3. Role of the Japan Consortium for International Cooperation in Cultural Heritage	74
5-4. Summary	74

Appendix	77
1. Laws Concerning Cultural Heritage Protection	77
2. List of Acquired Materials	118

1. Introduction

1-1. The Philippines

The Philippines is an archipelago of some 7,100 islands, located in the northwestern area of the Pacific Ocean, among an intricate geography of continental regions and small island regions. The group of islands also forms the eastern boundary of the inland sea region of the South China Sea along with Taiwan to its north and the island of Borneo to its south. The country as a whole covers an area from 4° 23' and 21° 25' north latitude to 116° to 126° 30' east longitude, and roughly forms the shape of an equilateral triangle with a 1,100 kilometers base from east to west and a height of 1,800 kilometers from north to south. It has a total area of approximately 300,000 square kilometers, corresponding to roughly 80% of Japan's total land area. The islands can be broadly divided into three regions: the northern region centered on the island of Luzon, the central region of the Visayas, composed of a large number of islands including Cebu, and the southern region centered on the island of Mindanao. These three regions are symbolically represented by the three stars depicted on the national flag. Administratively, the country is divided into 1 autonomous region, 13 regions and 73 provinces.

The country has a total population of 94.01 million as of the 2010 national census. The majority of the population displays Southern Mongoloid traits, but mountain regions and isolated coastal regions are also inhabited by a small minority of Negritos, characterized by short stature, dark skin and woolly hair. The Negritos are considered to have found their way to the Philippine islands before people of the Southern Mongoloid race arrived. Until recent years, they led a nomadic lifestyle mainly based on gathering, hunting and fishing as subsistence, but today, many have also taken to slash and burn cultivation. The different peoples comprising the ethnic group inhabit respective areas in the Philippines, and have distinct names, such as Ita, Agta, Aeta, Ati and Mamanuwa.

The religious distribution of the Philippines is said to be broadly represented by three religious-cultural spheres, including the Christian cultural sphere, Muslim cultural sphere, and a mountain-animism cultural sphere (Terada 1992:28). It is said that the first religious-cultural sphere, the Christian sphere, took shape as a result of a large number of people converting to Catholicism beginning in the 16th century, when the country was placed under Spanish colonial rule and was missionized by Catholic priests. The second cultural sphere, the Muslim sphere, is said to be distributed mainly in the southern part of the country, and is represented by 13 ethnic groups, including the Marano, Magindanao, Tausug, Sama and Bajao peoples. The third cultural sphere, the mountain-animism sphere, is said to be composed mainly by the Ifugao and Kalinga peoples who inhabit the mountain regions in northern Luzon, the Mangyan people of Mindoro Island, and minority ethnic groups who live in the highlands of Panay and Mindanao (Terada 1992:28-29).

Looking at ethnic groups in the Philippines from a linguistic perspective, languages spoken are diverse, and are said to surpass 100 in number (Tsuchida 1992:6). Almost all of these languages belong to the Austronesian language family. Ethnic groups who spoke the Austronesian language are believed to be natives of South China, who migrated to Taiwan and eventually to the Philippines. The languages of ethnic minorities in Taiwan therefore also belong to the Austronesian language family. Meanwhile, the Austronesian peoples who reached the Philippines are believed to have migrated southward from the Philippines to Borneo and further south to the islands of Indonesia, and thereafter branched out in two directions, with one group spreading to Polynesia and Micronesia by way of Melanesia, and the other group crossing the Indian Ocean to Madagascar on the east coast of Africa (Bellwood 1997). As a result, Austronesian languages came to be dispersed throughout an extremely large area, as is seen today. The Austronesian peoples who migrated from Taiwan to the Philippines and other islands of Southeast Asia also brought with them a material culture represented by pottery, square stone adzes and rice (Bellwood 1997). Elucidating the migration and migration routes of these Austronesian people has been a

large focus of studies by Peter Bellwood, a professor at the Australian National University. From early on, he took particular note of the fact that pottery displaying similar patterns as the earliest earthenware in Micronesia and Melanesia was found at the Magapit Shell Midden Site that is introduced in detail in the main body of his book, and discusses the monument in his general work (Bellwood 1997:221).

1–2. Archaeological heritage in the Philippines

Archaeological activities in the Philippines were spearheaded in the late 19th century by Alfred Marche, a French explorer who studied cave remains on Marinduque Island (Marche 1970:166). However, such activities were first systematized by H.O. Beyer, a professor at the University of the Philippines who undertook archaeological activities in earnest in the 1920s. Beyer conducted an organizational survey in the provinces of Rizal and Bulacan near Manila from 1926 to 1930, and a survey in Batangas Province south of Manila from 1932 to 1941, and compiled a comprehensive review of the Philippines' archaeological resources based on the numerous artifacts he collected from these surveys, combined with artifacts that were brought to him from various regions of the country (Beyer 1947). The review was chronologically categorized by island, or by province in cases where an island was large and had many provinces, according to the following time period classification: Paleolithic Age (50,000–20,000 years ago), Mesolithic Age (20,000 years ago–6000B.C.), Neolithic Age (6000B.C.–200B.C.), Iron Age (200B.C.–9th century), Porcelain Age (9th century–1521), and Spanish era (1521 and after). In 1948, he further subdivided the Neolithic Age into four periods based on the characteristic shapes of stone adzes (Beyer 1948): Pre-Neolithic Age (6000B.C.–4000B.C.), characterized by stone adzes with ground blades; Lower Neolithic Age (4000B.C.–2250B.C.), characterized by cylindrical stone adzes; Middle Neolithic Age (2250B.C.–1750B.C.), characterized by ridged or shouldered stone adzes; and Upper Neolithic Age (1750B.C.–200B.C.), characterized by square stone adzes. The framework Beyer created, however, was based on materials he either collected from the ground surface or discovered by chance, so it presented a few flaws, such as that it failed to provide evidence of the stratigraphic relationship and association of the artifacts.

In contrast to Beyer, R.B. Fox traced the history of the prehistoric culture by conducting concentrated archaeological excavations in a single region. From July 1962 to 1966, he surveyed more than 200 caves and rock shelters in the Quezon district along the west coast of central Palawan in western Philippines, and discovered artifacts on the surface of 64 caves and rock shelters (Fox 1970:11). Among these, 29 caves and rock shelters were discovered at Lipuun Point, the main area of the survey, of which 16 were excavated. Based on these excavations, Fox shed light on the cultural history of the region from the Paleolithic Age to the Age of Trade. In other words, based on representative caves and rock shelters and their occupation layers, a theory of the transition of eras emerged, beginning with the Upper Paleolithic Age (50,000–9,500 years ago) and moving on into the Late Upper Paleolithic Age (5000B.C.–2000B.C.), Lower Neolithic Age (4500B.C.–2500B.C.), Upper Neolithic Age (1500B.C.–700B.C.), Early Metal Age (500B.C.–100B.C.), Developmental Metal Age (200B.C.–900A.D.), and the Age of Trade (latter half of 10th century – beginning of 14th century)¹. This transition of eras has served as a basic standard to this day.

¹ There may be an interval between two periods or an overlapping of periods, because the transition of eras is based on actual sites and their occupation layers. The intervals mean that sites corresponding to that period in time had not been surveyed at the time Fox established the transition of eras. Additionally, there is some overlapping between two consecutive periods, due to discrepancies between the dates of an era determined from the content of the assemblage of artifacts and the dates determined from carbon dating or the estimated dates of monuments belonging to that period or their occupation layers. This can be interpreted as meaning that the beginning and end of each period are not fixed, but Fox did not give full consideration to this issue.

Reference

- Tanaka, K. 2010 Prehistory of the Philippines. in Kikuchi, S. and Abe, Y. (eds.) *Route of the Sea –from Indochina Peninsula to Japan-* : 66-90. (in Japanese).
- Tsuchida, S. 1992 Language. in Suzuki, S. and Hayase, S. (eds.) *Encyclopedia of the Philippines*. Douhoushya: 6-7. (in Japanese).

- Terada, T. 1992 Religion. in Suzuki, S. and Hayase, S. (eds.) *Encyclopedia of the Philippines*. Douhoushya: 28-30. (in Japanese)
- Bellwood, P. 1997. *Prehistory of the Indo-Malaysian Archipelago*. Revised edition. Honolulu: University of Hawaii Press.
- Beyer, H.O. 1947. Outline review of the Philippine archaeology by islands and provinces. *The Philippine Journal of Sciences* 77(3-4): 225-390.
- Beyer, H.O. 1948. Philippine and East Asian archaeology, and its relation to the origin of the Pacific Islands population. *Bulletin of the National Research Council of the Philippines* 29: 1-130.
- Fox, R.B. 1970. *The Tabon Caves -Archaeological explorations and excavations on Palawan Island, Philippines-*. Monograph of the National Museum. No.1, Manila.
- Marche, A. 1970. *Luzon and Palawan*. Translated from the French by Carmen Ojeda and Jovita Castro. The Filipiniana Book Guild. Manila.

1–3. Historic Buildings in the Philippines

Historic buildings in the Philippines can be grouped into three categories: religious facilities (churches, monasteries, tombs, etc.), public facilities (city walls, military facilities, watchtowers, etc.), and residences. Towns and villages principally display the grid city layout of the Spanish era with the largest district occupied by the church block in the center of the city and an open plaza in front of the church. In coastal towns, the church and plaza are located facing the sea.

Religious buildings are found throughout the country. A colonial-era document kept by a Spanish church notes that there were as many as 994 such buildings. Many of the churches in the country were built by missionary priests who came to the Philippines to spread the Catholic faith. The church, bell tower, and monastery are the three principal buildings of religious architecture. A typical church plan has an attached monastery and a cathedral. The façade design is a mixture of Romanesque, Gothic, Renaissance, and Baroque styles.

The main nave of the church is typically from 80 to 100 meters long and about 22 meters wide. The church building is made of massive stone walls that are 1 to 2 meters thick and 10 to 12 meters high, with a buttress at 3 to 5 meter intervals. The walls are made of multiple layers of stone block materials and brick, along with coral stones. The roof is made of wood, and is covered with roofing tiles.

The bell tower sometimes served as a watch tower for witnessing enemy attacks and assaults. Usually the bell tower circular or polygonal in shape and approximately 30 to 50 meters high, and was built either adjacent to the church, a few meters away from the church, or attached to the church.

The Spanish era fortress system in the Philippines was built over a period of three centuries, to hold out against various enemies (China, the Netherlands, England, etc.). The defense system consisted of fortresses composed of a fort and a multiple number of other structures (watch tower, church, fort city, small forts, signal tower). There are as many as 432 fortresses in the Philippines, but the number of fortresses that have been recognized as cultural heritage is not clear.

According to archaeological evidence, homes of Filipino villagers built during the early Spanish era were located in places where slash and burn agriculture could be performed and where water could be secured. They were built using light, pliable materials such as nipa (palm frond) and bamboo. Houses were high-floored to protect against insects and wild animals, and to keep away from the heat of the ground and from humidity during the rainy season. The pillars and beams were made of wood and bamboo, while the walls were made of boards, tree bark, nipa and bamboo. The roof was either a hipped, gabled or pyramidal roof, and made of wood and bamboo. Each region had its own unique style of house.

During the Spanish era, houses (bahay na bato) came to be made of stone and wood, and were more permanent and stronger than previous houses. Literally meaning “stone house,” bahay na bato were two story houses with an overhanging second floor. They had pillars made of a type of wood called molave, and walls made of stone and sun-dried brick. The roof was made of roofing tiles or nipa, but in many cases, it was later replaced by an iron roof.

As not many surveys and studies on architecture have been conducted in the Philippines, the works of recent researchers are worthy of mention. They include studies of architecture and urban planning in the Philippines

by Robert R. Reed, Lourdes Díaz-Trechuelo and Klassen Winand in particular, and some important studies of folk houses by Fernando N. Zialcita, Erik Akpedonu and Czarina Saloma. Extensive studies of colonial-era buildings (including churches and forts) and artwork have also been conducted by Pedro G. Galende and René B. Javellana. In Japan, studies are being conducted mainly by Prof. Shuji Funo of The University of Shiga Prefecture, and by Kiyoko Yamaguchi and Juan Ramon Jimenez Verdejo.

2. Study Overview

2-1. Objective

The Japan Consortium for International Cooperation in Cultural Heritage conducts studies of countries in need of assistance in conservation efforts with the objective of promoting Japan's engagement in international campaigns for the protection of worldwide cultural heritage. The studies focus on the state of cultural heritage protection in the country in need of assistance and on international cooperation initiatives of foreign countries in the field of cultural heritage. There are two types of studies: emergency studies aiming to rescue cultural heritage damaged by a natural disaster or other such situation by assessing damage, and regular studies that are conducted to collect information for future assistance for cultural heritage protection at the request of foreign countries. The countries for which the Consortium has conducted such studies in the past include Laos and Mongolia in fiscal 2007, Australia, Yemen, Germany, Norway and Sweden in fiscal 2008, Bhutan in fiscal 2009, Armenia and Micronesia in fiscal 2010, and Bahrain and Myanmar in fiscal 2011. This particular study was launched in fiscal 2012 in response to a request for assistance from the Philippines, and was conducted to assess the status of cultural heritage protection and international cooperation in the Philippines with a view to exploring future potential for cooperation by Japan.

2-2. Implementation Period

February 14 - 25, 2013 (12 days)

2-3. Study Team Members (the occupations were as of the implementation time)

- Kunikazu Ueno (Specially-appointed Professor, Center for Research of Ancient Culture, Nara Women's University) <Architectural history>
- Rei Harada (Researcher, Japan Consortium for International Cooperation in Cultural Heritage) <Cultural heritage protection systems and international cooperation>
- Kazuhiko Tanaka (Lecturer, Institute of Asian Cultures, Sophia University) <Philippine archaeology>
- Juan Ramon Jimenez Verdejo (Associate Professor, Department of Design and Architecture, School of Environmental Science, The University of Shiga Prefecture) <Spanish era architectural history, Urban history>

2-4. Content of the Study

The study team aimed to assess the present state of international cooperation on cultural heritage in the Philippines and gain a perspective on future cooperation. With a view to clarifying the Philippine side's request for cooperation, the team mainly visited sites inscribed on the World Heritage List and Tentative List, as well as museums and libraries throughout the country, to collect information and exchange views through interviews with relevant authorities of those sites.

2-5. Background to the Study

In July 2012, Rei Harada and others participated in the First ASEAN Plus Three Cultural Cooperation Network hosted by the Philippines, and took the occasion to interview officers from the National Commission for Culture and the Arts, the sponsor of the event, on the state of cultural heritage protection in the Philippines and requests

for cooperation from Japan, and confirmed the need for Japan's assistance.

It was understood that no comprehensive surveys on the state of cultural heritage protection have been conducted to date in the Philippines, but as the country is subject to frequent natural disasters, crisis management of cultural heritage is sought. Furthermore, with 2013 marking the 40th anniversary of ASEAN-Japan relations, requests for further cooperation from Japan are expected to increase in the ASEAN region. Based on an understanding of this situation, a proposal was made to implement a country assistance study in the Philippines to gather information that would be needed in preparation for providing assistance in the field of cultural heritage, and was approved at the Consortium's planning subcommittee meeting held in September 2012.

2-6. Study Method

There are many national institutions that administer to matters related to cultural heritage protection in the Philippines, but as the National Commission for Culture and the Arts plays a central role, the study team contacted the International Department under the National Commission for Culture and the Arts in advance to verify the necessary procedures for implementing a study in the Philippines and methods for establishing communication with relevant authorities.

The team also asked the department to specify cultural heritage sites for which Japan's cooperation is sought, but since no specific sites were named by the department, the survey team examined various cultural heritage sites among themselves and selected those which would be appropriate for the study. The selection of heritage was based on the assumption that the Philippine side probably places particular importance on those heritage sites that are inscribed on the World Heritage List and Tentative List. From among such heritage, priority was given to those sites that could benefit from future cooperation from Japan, those that are reported to be in danger, and those for which detailed information cannot be obtained in Japan, and a final selection was made in consideration of the study schedule. As the list of selected sites was sent to the International Department in advance, an officer from the National Commission for Culture and the Arts accompanied the study team in some cases to provide explanations.

The study also included interviews with people concerned with cultural heritage protection in the Philippines. In the capital city, the National Commission for Culture and the Arts kindly arranged interviews with relevant institutions based on a list of potential interviewees the study team sent to the Commission in advance, and a Commission officer accompanied the team on the interviews.

Contact with the National Commission for Culture and the Arts was made through the cooperation of Ms. Maricel C. Diaz, an acquaintance of Rei Harada in the Commission's International Department. During the preparatory period prior to departure, the study team also engaged in an active exchange of information with Philippine experts in Japan.

2-7. Interviews

During the study period, interviews were mainly held with a total of some 35 officers in the National Commission for Culture and the Arts and other personnel engaged in matters related to cultural heritage protection. The table right shows the interviewees in the order in which they were interviewed.

Table1 List of Interviewees

Name	Title	Affiliation
Wilfredo P. Ronquillo	Curator II, Archaeology Division Scientist II, DOST/CSC	National Museum
Ame M. Garong	Museum Researcher Archaeologist	National Museum
Rene B. Javellana	Associate Professor Fine Arts Program	Ateneo De Manila University
Jaime L. Sy	Owner	HoTong Hardware, Inc.
Jason K. Dy	Parochial Vicar	Sacred Heart Parish
Florencia Jojie G. Pestelos	Staff Member	Baclayon Ancestral Homes Association (Bahandi)
Donald Abraham Lara	Engineer Officer	Dalaguete Town Office
Eva Marie S. Medina	City Mayor	Vigan City
Janina Carine Medina-Farinas	Consultant	Vigan City
Edred D. Piamonte	Public Relations and Information Officer	Vigan City
Edgar B. De La Cruz	City Tourism/Investment Promotion Officer	Vigan City
Miran Ted Torralba	Vice-Head	NCCA Sub-Commission on Cultural Heritage
Kiyoshi Takeuchi	Director	Japan Information and Culture Center Embassy of Japan in the Philippines
Kazuto Okazaki	First Secretary	Embassy of Japan in the Philippines
Emelita V. Almosara, Ces0 IV	Executive Director III	National Commission for Culture and the Arts
Virginia A. Miralao	Secretary-General	UNESCO National Commission of the Philippines Department of Foreign Affairs
Jesus T. Peralta	Consultant	National Commission for Culture and the Arts
Cecilia V. Picache	National Living Treasures and Intangible Cultural Heritage Programs Planning Officer III	National Commission for Culture and the Arts
Maricel C. Diaz	Office-in-Charge	National Commission for Culture and the Arts
Ludovico D. Badoy	Executive Director III	National Historical Commission of the Philippines
Wilkie B. Delumen	Chief Architect Historic Preservation Division	National Historical Commission Historic Preservation Division
Reynaldo S. Lita	Architect	National Historical Commission of the Philippines
Romel Aquino	Architect	National Historical Commission of the Philippines
Victorino Mapa Manalo	Executive Director	National Archives
Antonio M. Santos	Director Professorial Lecturer in Law and Library Science	National Library
Dolores D. Carungui	Acting Chief Reference Division	National Library
Angel P. Bautista	Chief Cultural Properties Division Office President	National Museum
Raquel Dc Flores	Curator I Cultural Properties Division Office President	National Museum
Mary Rajelyn Javier-Busmente	Architect	National Commission for Culture and the Arts
Richard Tuason-Sanchez Bautista	Architect	Not determined
Roden T. Santiago	Staff	Angono Site
Kemmiya Misa	Administration and Coordination Section	Japan International Cooperation Agency Philippine Office
Matsuda Hiroyuki	Representative Economic Growth Section	Japan International Cooperation Agency Philippine Office
Takatori Shuji	Director	The Japan Foundation, Manila
Mitomi Yukie	Assistant Director	The Japan Foundation, Manila

2–8. Activity Record

Within a short study period of twelve days, the study team surveyed a total of some 30 archaeological sites and historical buildings and toured approximately 14 museums and related facilities. The following is a list of these sites and facilities.

Table2 Activity Log

Date	Area	City	Site Name	World Heritage List
2013/2/14	Central Luzon	Manila	National Museum, Archaeology Division	
2013/2/15	Northern Luzon	Lalo, Cagayan	Magapit Shell-midden	Tentative (Culture)
	Northern Luzon	Lalo, Cagayan	Lal-lo Church	
	Northern Luzon	Lalo, Cagayan	Fort Lal-lo	
2013/2/16	Northern Luzon	Camalaniugan, Cagayan	Camalaniugan Church	
	Northern Luzon	Peñablanca, Cagayan	Callao Cave	Tentative (Culture)
2013/2/17	Northern Luzon	Iguig, Cagayan	Atulu	
	Cebu	Cebu City	Casa Gorordo (Museum)	
	Cebu	Cebu City	Jesuit House of 1730	
	Cebu	Cebu City	Fort San Pedro	
	Cebu	Cebu City	Basilica Minore del Santo Niño	
2013/2/18	Cebu	Cebu City	Cebu Metropolitan Cathedral	
	Bohol	Tubigon	Church of Isidore the Farmer	
	Bohol	Loon	Church of Nuestra Señora de la Luz	
	Bohol	Maribojoc	Santa Cruz Church	
	Bohol	Cortes	Santo Niño Church	
	Bohol	Loboc	Church of San Pedro	Tentative (Culture)
2013/2/19	Bohol	Baclayon	Baclayon Ancestral Homes Association (Bahandi)	
	Southern Cebu	Naga	Church of San Francisco de Asís	
	Southern Cebu	Carcar	Church of Santa Catalina de Alejandria	
	Southern Cebu	Sibonga	Church of Nuestra Señora del Pilar de Zaragoza	
	Southern Cebu	Argao	Church of San Miguel el Arcángel	
	Southern Cebu	Dalaguete	Church of San Guillermo de Aquitania	
2013/2/20	Southern Cebu	Boljoon	Church of Patrocinio de Maria	Tentative (Culture)
	Southern Cebu	Oslob	Church of Inmaculada Concepción	
2013/2/21	Cebu	Cebu City	Museo Cebu (Museo Sugbo)	
	Cebu	Cebu City	Cathedral Museum of Cebu	
	Northern Luzon	Santa Maria, Illocos Sur	Santa Maria Church	Culture (1993)
	Northern Luzon	Narvacan, Illocos Sur	Santa Lucia Church	
	Northern Luzon	Vigan City, Illocos Sur	Vigan City	Culture (1999)
2013/2/22	Northern Luzon	Vigan City, Illocos Sur	Vigan City Office	
	Northern Luzon	Paoay, Illocos Norte	San Agustin Church	Culture (1993)
	Central Luzon	Manila	Embassy of Japan in the Philippines	
	Central Luzon	Manila	National Commission for Culture and the Arts (NCCA)	
	Central Luzon	Manila	National Historical Commission of the Philippines	
	Central Luzon	Manila	National Archives	
2013/2/23	Central Luzon	Manila	National Library	
	Central Luzon	Manila	National Museum	
	Central Luzon	Manila	Casa Manila Museum	
2013/2/24	Central Luzon	Manila	San Agustin Church	Culture (1993)
	Central Luzon	Manila	Basilica Minore de San Sebastián	Tentative (Culture)
2013/2/25	Central Luzon	Manila	Shop houses in Binondo (China Town)	
	Central Luzon	Angono	Angono Site	Tentative (Culture)
2013/2/25	Central Luzon	Manila	JICA Philippine Office	
	Central Luzon	Manila	The Japan Foundation, Manila	

2–9. Reason for Selecting the Philippines for the Study

With regard to Philippine-Japan relations, the Japanese government signed a reparations treaty with the Philippine government in 1956, and commenced its first grant aid to the country in 1969. Japan remains the largest donor country to the Philippines still today. Japan's Cultural Grant Assistance to the Philippines commenced in 1976, and a total of 1,878 billion yen has been granted to 44 projects as of fiscal 2012.

The country is blessed with a rich and diversified cultural heritage, as seen in colonial-era cityscapes and churches, the rice terraces that are a representative cultural landscape in the Philippines, and prehistoric archaeological sites. Japanese cooperation for cultural heritage protection in the Philippines includes the archaeological excavation of prehistoric ruins in Luzon conducted continuously since the 1970s by a team from Sophia University led by Prof. Yoji Aoyagi, and an ethnological study of folk houses conducted by Koji Sato, Associate Professor at the National Museum of Ethnology, in the 1980s. Some of the more recent cooperation includes a



Fig.1 Wide-area map of the Philippines

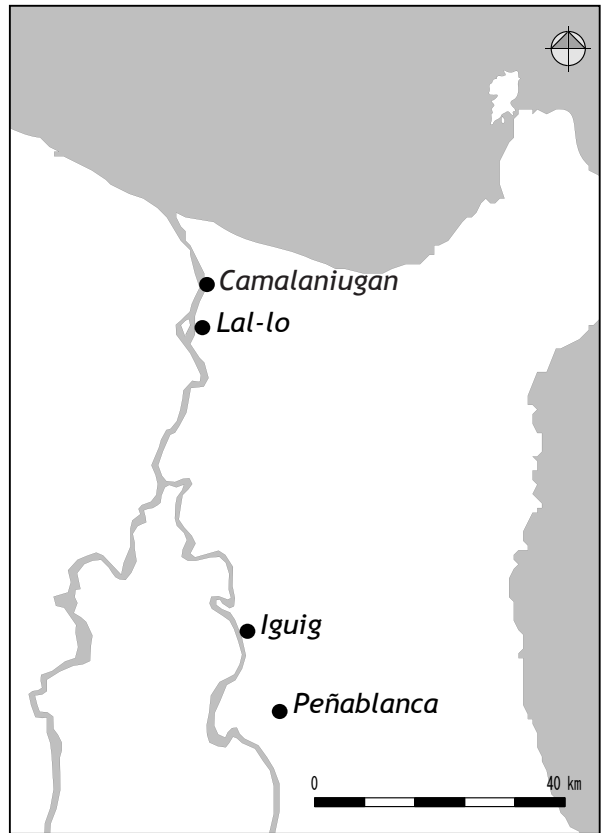

Fig.2 Detailed map of the Philippines (Cagayan)

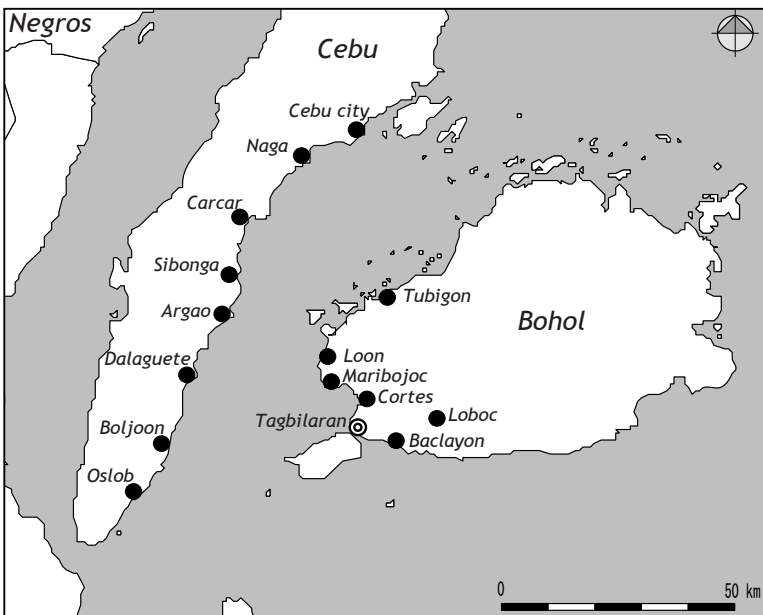

Fig.3 Detailed map of the Philippines (Cebu and Bohol)

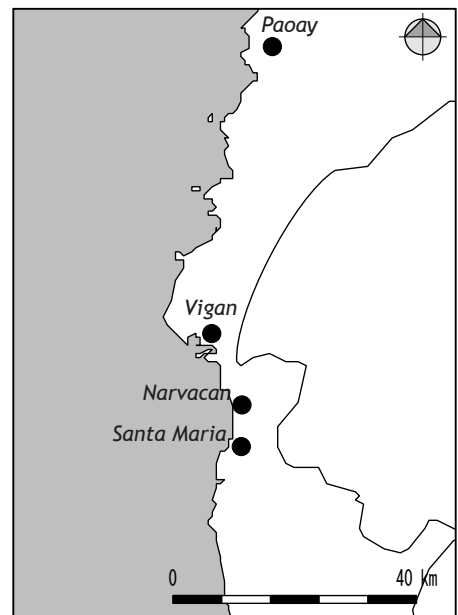

Fig.4 Detailed map of the Philippines (Vigan)

human resource development program implemented by the Cultural Heritage Protection Cooperation Office of the Asia-Pacific Cultural Centre for UNESCO (ACCU Nara Office) in the 2000s; seminars on conservation of Asian cultural heritage which have included the Philippines among their scope of countries, organized by National Research Institute for Cultural Properties, Tokyo over a period of five years from 2002; cooperation for protection of intangible cultural heritage by the Ministry for Foreign Affairs of Japan and UNESCO, Japanese Funds-in-Trust for the Preservation and Promotion of Intangible Cultural Heritage, which has continued for a period of five years from 2003; a study on the cultural landscape of the rice terraces of the Cordilleras by a team from Tsukuba University led by Prof. Nobuko Inaba; and a study on urban planning by Prof. Shuji Funo of the University of Shiga Prefecture. When funding assistance to local researchers by the Toyota Foundation and Sumitomo Foundation is included, Japan's cooperation has been extended to almost 30 studies and research projects related to Philippine cultural heritage.

However, studies to date have been conducted separately in each relevant field, such as architecture, cultural anthropology and archaeology, and no cross-disciplinary studies have been conducted to address cultural heritage protection as a whole. Even when comparing the situation with neighboring Southeast Asian countries, there has only been a limited number of cases of Japanese cooperation in the Philippines, and information on cultural heritage protection is lacking, as well. Furthermore, as the country is subject to frequent typhoons, earthquakes and other natural disasters, there is a strong need for crisis management in regard to cultural heritage. In fact, in October 2013 shortly after the study, an earthquake struck Cebu and Bohol and brought damage to cultural heritage that is included on the World Heritage Tentative List, as well as to many other buildings. In November, the following month, Typhoon Haiyan made landfall in the Visayas and seriously affected some 16 million people.

2013 marks the 40th anniversary of ASEAN-Japan relations, and as greater cooperation from Japan is expected to be sought in the ASEAN region, it is becoming necessary to gather information and prepare to provide assistance also in the field of cultural heritage protection. In July 2013 following completion of the study, Prime Minister Abe held a summit meeting in the Philippines during his visit to Southeast Asia, and announced a new initiative that included further promotion of personnel exchanges, which confirmed Japan's commitment to strengthening relations between the Philippines and Japan. In consideration of such bilateral diplomatic policies of late and the overall situation regarding cultural heritage protection in the Philippines, the Japan Consortium for International Cooperation in Cultural Heritage affirmed the strong need to confirm and gather relevant information on the latest status of cultural heritage protection in the Philippines with a view to promoting cooperation in that area, and to accurately assess the areas in which Japanese experts and relevant institutions could extend their cooperation in the future. As the two countries' relationship deepens even further and many more people are expected to engage in cultural heritage protection in the Philippines hereafter, the Consortium will assume what it believes is its expected role in initiating the collection of basic information and creating a foundation for cooperation toward the effective implementation of cultural heritage protection in the Philippines.

3. Framework for Cultural Heritage Protection in the Philippines

3-1. National Overview

Before discussing the cultural heritage protection framework in the Philippines, this section provides an overview of the country and its government system.

The Philippines was ruled by Spain from 1571, and thereafter by the United States following the Spanish-American War in 1898. From 1942, it was placed under Japanese military control, but gained independence as the Republic of the Philippines in 1946 after the end of World War II.

The country adopts a constitutional republic form of government headed by President Benigno Aquino III since June 2010 (6-year term with no re-election). The Congress is bicameral, with a 24-seat Upper House and a maximum 291-seat Lower House. As of February 2013, the following 27 ministers are appointed to the Cabinet.¹ The list does not include the National Commission for Culture and the Arts, as will be discussed later in section 3-3.

Cabinet Secretary	Secretary of Justice
Executive Secretary	Secretary of Labor and Employment
Head of the Presidential Management Staff	Secretary of National Defense
Presidential Spokesperson	Secretary of Public Works and Highways
Secretary of Agrarian Reform	Secretary of Science and Technology
Secretary of Agriculture	Secretary of Social Welfare and Development
Secretary of Budget and Management	Secretary of Tourism
Secretary of Education	Secretary of Trade and Industry
Secretary of Energy	Secretary of Transportation and Communications
Secretary of Environment and Natural Resources	Director-General of the National Economic and Development Authority
Secretary of Finance	Chief Presidential Legal Counsel
Secretary of Foreign Affairs	Presidential Adviser on the Peace Process
Secretary of Health	National Security Adviser
Secretary of the Interior and Local Government	

3-2. Laws Concerning Cultural Heritage

It is considered that cultural heritage surveys, studies and conservation activities in the Philippines were not conducted in particular during the Spanish era, and although large volumes of administrative documents exist, no specific mention has so far been found on survey activities related to cultural heritage protection. Major laws that are currently in effect for cultural heritage protection in the Philippines include the two listed below and supplementary rules and regulations.

- [Republic Act No. 10066]

An Act Providing for the Protection and Conservation of the National Cultural Heritage, Strengthening the National Commission for Culture and the Arts (NCCA) and Its Affiliated Cultural Agencies, and for Other Purposes

- [Rules and Regulations of Republic Act No. 10066]

Implementing Rules and Regulations of Republic Act No. 10066, "An Act Providing for the Protection and Conservation of the National Cultural Heritage, Strengthening the National Commission for Culture and the Arts

¹ Ministry of Foreign Affairs, "Republic of the Philippines." <http://www.mofa.go.jp/mofaj/area/philippines/index.html>

(NCCA) and Its Affiliated Cultural Agencies, and for Other Purposes”

• [Republic Act No. 10086]

An Act Strengthening Peoples’ Nationalism through Philippine History by Changing the Nomenclature of the National Historical Institute into the National Historical Commission of the Philippines Strengthening Its Powers and Functions, and for Other Purposes

In this study, a booklet containing English translations of legal texts was obtained from the Philippine government and was therefore used as reference. It should be noted that the above laws were originally written in English. This section discusses [Republic Act No. 10066] in general, as it is considered to have particular significance among the above laws.²

[Republic Act No. 10066] is referred to as the “National Cultural Heritage Act of 2009” in abbreviated form, and is composed of 15 articles that provide for three goals: (a) Protect, preserve, conserve and promote the nation’s cultural heritage, its property and histories, and the ethnicity of local communities; (b) Establish and strengthen cultural institutions; and (c) Protect cultural workers and ensure their professional development and well-being. As each of the articles in [Republic Act No. 10066] is linked to the provisions in [Rules and Regulations of Republic Act No. 10066], an explanation of particularly important matters in [Republic Act No. 10066] is given below, with supplementary reference to relevant rules and regulations.

First of all, “Definition of Terms” defines the following six national institutions as cultural organizations, and identifies their specific responsibility in their designated areas (Articles 2 and 8).

National Museum :

Cultural property. Conservation of important movable and immovable assets relating to fine arts, archaeology, anthropology, botany, geology, zoology and astronomy.

National Library of the Philippines (formerly named National Library) :

Books. Repository particularly of presidential papers, periodicals, and rare or important books.

National Historical Commission of the Philippines (formerly named National Historical Institute) :

History of the Philippines. Conservation of significant movable and immovable cultural property that pertains to Philippine history and heroes.

National Archives of the Philippines (formerly named Records, Management, and Archives Office) :

Ancient archival materials.

Cultural Center of the Philippines :

Protection of important cultural assets related to culture, arts and performing arts.

Komisyon sa Wikang Filipino / Commission on the Filipino :

Dissemination and development of the Filipino language and conservation of ethnic languages.

Next, it is stipulated that Cultural Heritage shall refer to the totality of cultural properties, and Cultural Property shall refer to all products of human creativity by which a people and a nation reveal their identity, whether publicly or privately-owned, movable or immovable, and tangible or intangible. Other major terms are defined as follows (Articles 2 and 4).

² Refer to Appendix 1. Laws Concerning Cultural Heritage Protection

NCCA ORGANIZATIONAL STRUCTURE

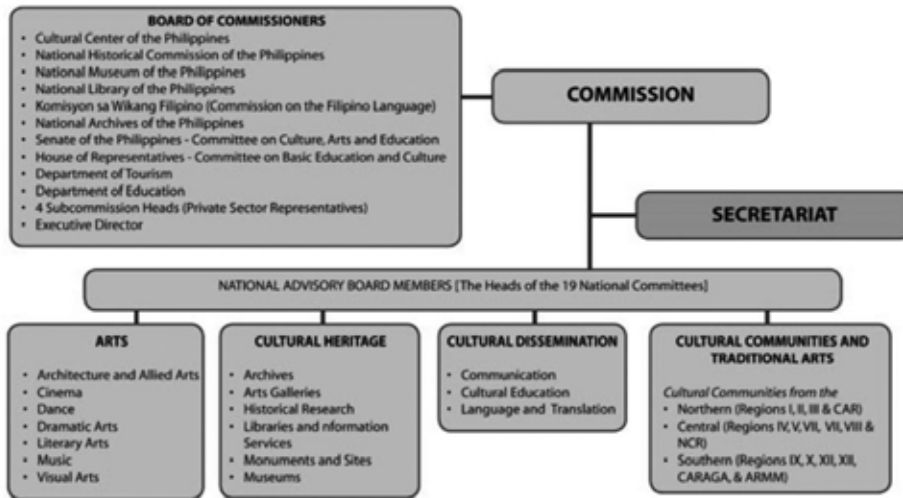

Fig.5 Organizational chart of the National Commission for Culture and the Arts (NCCA) (<http://www.ncca.gov.ph/about-ncca/about-ncca/about-ncca-history-mandate.php>)

THE GOVERNING BOARD OF COMMISSIONERS



Fig.6 Organizational chart of the Governing Board of Commissioners of the National Commission for Culture and the Arts (NCCA) (<http://www.ncca.gov.ph/about-ncca/about-ncca/about-ncca-history-mandate.php>)

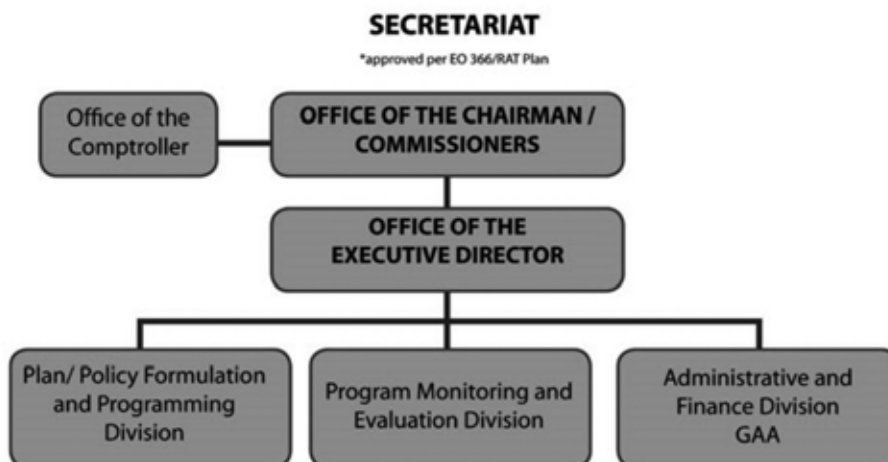

Fig.7 Organizational chart of the Secretariat of the National Commission for Culture and the Arts (NCCA) (<http://www.ncca.gov.ph/about-ncca/about-ncca/about-ncca-history-mandate.php>)

Heritage Zone : Historical, anthropological, archaeological, artistic geographical areas and settings that are culturally significant to the country, as declared by the National Museum and/or the National Historical Commission of the Philippines. Heritage Zones are maintained and managed by local governments.

Historical Landmark : Sites or structures that are associated with events or achievements significant to Philippine history as declared by the National Historical Commission of the Philippines.

Heritage Monument : Structures that honor illustrious persons or commemorate events of historical value as declared by the National Historical Commission of the Philippines.

Historical Shrine: Historical sites or structures hallowed and revered for their history or association as declared by the National Historical Commission of the Philippines.

Important Cultural Property : Cultural property having exceptional cultural, artistic, and historical significance to the Philippines, as shall be determined by the National Museum and/or National Historical Commission of the Philippines.

National Treasure : Unique cultural property possessing outstanding value, and officially declared as such by the pertinent cultural agency.

There is also the Philippines Registry of Cultural Property of all cultural properties of the country.

Furthermore, national treasures are classified as follows (Article 3).

Grade 1 : World Heritage Sites, National Treasures, Historical Landmarks, Historical Shrines, Heritage Monuments

Grade 2 : Important Cultural Properties

Grade 3 : Cultural Properties not designated as Grade 1 or 2 properties

Structures dating at least fifty years old are considered Important Cultural Properties, and stipulations are provided for priority government funding for their protection, conservation and restoration; procedures of designation, delisting, purchasing and selling national cultural treasures or important cultural properties.

[Republic Act No. 10066] also stipulates the powers provided to each national cultural institution for proper protection of cultural heritage (Article 7). Especially important is that the National Museum regulates and controls all anthropological research conducted by foreigners; that all anthropological research is to be undertaken only by the authority and under the supervision of the National Museum; and that all cultural properties found in archaeological sites belong to the State. Also characteristic of the Act is that it stipulates cooperation between the National Museum and local governments in cases where a cultural property has been discovered in a site where exploration for treasures has been permitted by the National Museum.

Subsequent articles include the following, introduced herein by title only: Article 5 "Registration and Conservation of Cultural Property," Article 6 "Regulating the Export, Transit, Import and Repatriation of Cultural Property," Article 9 "Cultural Property Incentives Program," Article 10 "Cultural Education," Article 11 "Cultural Heritage Worker's Incentives Program," Article 12 "Sentro Rizal," Article 13 "Penal Provisions," Article 14 "Endowment," and Article 15 "Final Provisions."

[Republic Act No. 10086], commonly referred to as "Strengthening Peoples' Nationalism Through Philippines History Act," contains 30 articles that provide for changing the nomenclature of the National Historical Institute to National Historical Commission of the Philippines, and for strengthening its powers and functions. It was approved in 2009, on the same date as [Republic Act No. 10066].

As treaties for the protection of cultural heritage, the Philippines ratified the Convention concerning the Protection of the World Cultural and Natural Heritage in 1985 and the Convention for the Safeguarding of the Intangible Cultural Heritage in 2006. World Cultural Heritage sites in the Philippines include the Baroque Churches of the Philippines (inscribed in 1993), the Rice Terraces of the Philippine Cordilleras (inscribed in 1995), and the Historic Town of Vigan (inscribed in 1999). In addition to these, there are a total of 19 sites on the World Heritage

Tentative List, including 13 cultural heritage sites (including 1 extended application), 15 natural heritage sites and 1 mixed heritage site. They are as follows: the Angono Trigrams, Baroque Churches of the Philippines (extended application), Batanes Protected Landscapes and Seascapes, Butuan Archaeological Sites, Jesuit Churches of the Philippines, Kabayan Mummy Burial Caves, Neolithic Shell Midden Sites in Lal-lo and Gattaran Municipalities, Paleolithic Archaeological Sites in Cagayan Valley, Petroglyphs and Petrographs of the Philippines, Spanish Colonial Fortifications of the Philippines, the Maranao Settlement of Tugaya, and the Tabon Cave Complex and all of Lipuun.³

3-3. Administration

Administrative and executive institutions for cultural affairs are prescribed in [Republic Act No. 10066] Article 2, Section 3 (j) as the six national government agencies defined as cultural agencies with specific areas of responsibility. To make a supplementary statement, it seems that the National Commission for Culture and the Arts (NCCA), the counterpart organization of this study, that actually plays a role to control the wide-ranging administration of cultural affairs including cultural heritage, promotes comprehensive cultural policies, and provides subsidies for cultural development and protection. The Commission was founded in 1987, five years after the predecessor Presidential Commission on Culture and Arts was established by then-President Aquino, based on [Republic Act No. 7356] (An Act Creating the National Commission for Culture and the Arts, Establishing National Endowment Fund for Culture and the Arts, and for Other Purposes). The Philippines does not have a ministry for culture, but the Commission assumes the operations of such a ministry for all practical purposes. The six principles of the Commission defined in [Republic Act No. 7356] include “preservation of the Filipino heritage.”

The Commission is composed of two assembly members (one each from the Upper and Lower Houses), the directors of the six national cultural agencies, the directors of the four subcommittees, the Undersecretary of the Department of Education, the Undersecretary of the Department of Tourism, and the Head of the National Commission for Cultures and the Arts. The six national cultural agencies are as identified earlier, and the four subcommittees are composed of 19 national commissions in which artists and private and public sector experts in cultural affairs participate.⁴

3 UNESCO Philippines Ratified Conventions http://www.unesco.org/eri/la/conventions_by_country.asp?language=e&contr=PH&typeconv=1 UNESCO World Heritage Centre <http://whc.unesco.org/en/statesparties/ph>

4 National Commission for Cultures and the Arts <http://www.ncca.gov.ph/main.php>

4. Cultural Heritage Sites in the Philippines

This chapter gives a brief overview of observations about the archaeological sites, historical buildings, museums and libraries that were visited and inspected in this study from the perspective of cultural heritage preservation. Needless to say, these are only a small part of the cultural heritage of the Philippines, but they were selected and based on the assumption that properties which the Philippine side considers particularly important are mainly sites that are inscribed on the World Heritage List or listed on the World Heritage Tentative List. From among such properties, those that could benefit from future cooperation from Japan, those that are reported to be in danger, and those for which detailed information cannot be obtained in Japan were preferentially selected for the survey. For each site, information is mainly provided of their general description (location, size, year of construction), characteristics, historical and cultural significance, present condition of protection (including their status of conservation and restoration and present foreign aid schemes), and are presented in the order in which they were visited, divided by area. The dates the sites were visited and their locations are as shown in Table 1 and Figs. 1 to 4.

With respect to cultural properties in isles of Cebu and Bohol, which suffered an earthquake in October 2013, a description of their state of damage from the earthquake has been added to the general description of their status as cultural properties. This was made possible by survey member Juan Ramon Jimenez Verdejo, who generously offered the results of his local survey, "Earthquake Research Survey on Bohol Island (Challenging Exploratory Research / General Research Fund)," which he conducted from November 8 to 18, 2013. In addition to Juan Ramon Jimenez Verdejo, the survey team also included Carlos Cordero Aguaded (graduated from Sevilla Architecture University, enrolled in the Department of Design and Architecture at the University of Shiga Prefecture). The team visited historical buildings in the region, including those that were included in the scope of the country assistance study and verified the state of earthquake damage. With the cooperation of Melva Java, Associate Professor at the University of San Carlos in Cebu, the team acquired information on 53 churches in Cebu and 23 churches in Bohol.

The overview of the earthquake is as follows, as announced by the U.S. Geological Survey (USGS).

Date & time : October 15, 2013; 8:12 a.m. local time

Epicenter : 9° 87' N latitude, 124° 11' E latitude (Bohol Island, Central Philippines)

38 kilometers northeast of Tagbilaran

624 kilometers south-southeast of Manila

Scale : M7.1; depth of epicenter 20 kilometers

According to an earthquake damage report issued by the Philippine government dated October 30, 2013, the earthquake claimed 222 lives (including 208 in Bohol (province) alone), left 797 people injured (including 692 in Bohol) and 8 missing, and affected more than 3 million people. Financial damage to roads, bridges and other public facilities totaled 2.2 billion pesos, and more than 66,000 homes were partly or wholly destroyed. A local news report dated October 22 quoted the governor of Bohol as saying that cultural properties in the province suffered damage worth several million pesos in terms of restoration expenses.

Thereafter on October 25, the United Nations and a humanitarian institution in the Philippines pledged assistance in the amount of \$468 million to residents affected by the earthquake, and on October 29, the Japanese government responded to a request from the Philippine government and pledged to provide emergency relief supplies (tents, plastic sheets, etc.) worth ¥38 million through the Japan International Cooperation Agency.

Furthermore, Japanese companies such as Toshiba, Epson and Canon also pledged to make monetary donations.

Table3 Damage situation of churches located in Cebu

(Juan Ramon Jimenez Verdejo 2013 Survey on Disaster effects on Philippines' Cultural Heritages. 24th Meeting of Southeast Asia Subcommittee, JCIC-Heritage)

CEBU ISLAND SPANISH COLONIAL CHURCHES- 15.10.2013 EARTHQUAKE DAMAGES														
		Bellfry	walls				Interior				Convent	Est %damage		
			Front	Rigth	Beside	Left	Altar	Ceiling	Floor	Sacristy		Structure	Interior	S+I
1	Pardo	2	1	0	0	0	0	0	0	0	0	15	0	7,5
2	Talisay	1	0	1	1	0	0	0	0	0	0	15	0	7,5
3	Minglanilla	0	1	1	0	1	0	0	0	0	0	15	0	7,5
4	Naga	0	1	1	0	1	0	0	0	0	0	15	0	7,5
5	San Fernando	1	2	1	1	1	0	0	0	1	0	30	5	18
6	Carcar	3	1	1	1	1	0	1	0	0	1	35	5	23
7	Sinbonga	2	1	2	1	2	1	0	0	1	1	40	10	28
8	Argao	1	1	1	1	1	0	0	0	0	0	25	0	13
9	Dalaguete	3	3	1	2	1	0	0	1	2	2	50	15	38
10	Alcoy	1	0	0	0	0	0	0	0	0	0	5	0	2,5
11	Boljoon	1	1	1	1	2	1	0	0	1	0	30	10	20
12	Oslob	0	0	1	0	1	0	0	0	0	0	10	0	5
12	Oslob	1	1	1	1	1	0	0	0	0	0	25	0	13
13	Santander	0	0	1	0	1	0	0	1	0	0	10	5	7,5
14	Samboan	3	2	2	0	0	0	0	0	0	0	35	0	18
15	Ginatilan	0	0	0	0	1	0	0	0	2	0	5	10	7,5
16	Malabayoc	2	2	0	0	0	0	0	0	0	0	20	0	10
17	Alegria	0	0	0	0	0	0	0	0	0	0	0	0	0
18	Badian	0	1	0	1	0	2	1	0	0	0	10	15	13
19	Moalboal	0	1	0	1	0	0	0	0	0	0	10	0	5
20	Alcantara	0	0	0	0	0	0	0	0	0	0	0	0	0
21	Ronda	1	1	0	0	0	0	0	0	0	1	10	0	7,5
22	Dumanjug	2	2	2	0	1	0	2	0	1	0	35	15	25
23	Barili	2	2	1	0	1	1	1	1	0	0	30	15	23
24	Aloguinsan	1	1	2	1	2	1	0	1	0	0	35	10	23
25	Pinamungajan	0	0	0	0	0	0	0	0	0	0	0	0	0
26	Toledo	0	0	0	0	0	0	0	0	0	0	0	0	0
27	Balamban	0	2	2	0	1	0	2	1	0	0	25	15	20
28	Asturias	2	0	0	0	0	0	0	0	0	0	10	0	5
29	Tuburian	0	0	0	0	0	0	0	0	0	0	0	0	0
30	Tabuelan	0	1	1	0	1	1	0	1	0	0	15	10	13
31	San Remigio	0	1	0	1	0	1	0	0	0	0	10	5	7,5
32	Santa Fe	0	0	0	0	0	0	0	0	0	0	0	0	0
33	Madridejos	0	0	0	0	0	1	0	0	0	0	0	5	2,5
34	Bantayan	0	1	0	0	2	0	0	0	0	0	15	0	7,5
35	Medellin	0	1	1	0	1	0	0	0	0	0	15	0	7,5
36	Daan Bantayan	0	0	0	0	0	0	0	0	0	0	0	0	0
37	Bogo	0	0	0	0	0	0	0	0	0	0	0	0	0
38	Tabogon	2	1	0	0	0	0	0	0	0	0	15	0	7,5
39	Borbon	0	1	0	0	0	0	0	0	0	0	5	0	2,5
40	Sogod	0	0	0	0	0	0	0	0	0	0	0	0	0
41	Catmon	0	0	0	0	0	0	0	0	0	0	0	0	0
42	Carmen	0	1	0	0	0	0	0	0	0	0	5	0	2,5
43	Danao	1	0	0	0	0	0	0	0	0	0	5	0	2,5
44	Compostela	0	0	0	0	0	0	0	0	0	1	0	0	2,5
45	Liloan	0	0	1	1	1	0	0	0	0	0	15	0	7,5
46	Consolacion	0	1	0	0	0	0	1	0	0	0	5	5	5
47	Mandaue	1	2	0	0	0	0	0	0	0	0	15	0	7,5
48	Lapu-lapu											0	0	0
49	Santo Nino	3	0	0	0	0	0	0	0	0	0	15	0	7,5
50	Cathedral	2	2	0	0	0	0	0	0	0	0	20	0	10
51	San Fr. Camotes	0	0	0	0	0	0	0	0	0	0	0	0	0
52	Poroc Camotes	0	1	0	0	0	0	0	0	0	0	5	0	2,5
53	Cordova	0	0	0	0	0	1	0	0	0	0	0	5	2,5



BOHOL ISLAND SPANISH COLONIAL CHURCHES 15.10.2013 EARTHQUAKE DAMAGES					
1 Loboc	4	9 Cortes	4	17 Clarin	4
2 Baclayon	3	10 Trinidad	3	18 Corella	3
3 Dauis	3	11 Inabanga	4	19 Panglao	3
4 Maribojoc	4	12 Lila	3	20 Tubigon	4
5 Loon	4	13 Bilar	3	21 Danao	3
6 Loay	3	14 Tagbilaran	3	22 Carmen	3
7 Dimiao	3	15 Sikatuna	3	23 Antequera	3
8 Calape	3	16 Talibon	3		

0	Non Damages
1	1-25% Damages
2	26-50% Damages
3	51-75% Damages
4	76-100% Damages

Fig.8 State of damage to churches located in Cebu and Bohol (Juan Ramon Jimenez Verdejo 2013 Survey on Disaster effects on Philippines' Cultural Heritages. 24th Meeting of Southeast Asia Subcommittee, JCIC-Heritage)

According to an announcement by the Association of National Committees of the Blue Shield (ANCBS) dated November 13, members of the Association for Preservation Technology International (APTI) in New York, USA and the NPO Bakas Philipinas are playing a central role in providing assistance for the preservation of historical buildings. The latter works with Tagbilaran District, and cooperates with ISCARSAH and ICORP of ICOMOS in proposing technical cooperation for reconstruction and restoration in Bohol to the Philippine government's Heritage Task Force (composed of NCCA, National Historical Institute (NHI), National Museum of the Philippines, and ICOMOS Philippines). Additionally, according to an announcement issued by the Philippine government on November 20, ASEAN pledged assistance of \$45,000 from the ASEAN Cultural Fund for restoration of cultural heritage in the affected regions. Furthermore, from December 4 to 11, UNESCO sent experts to the islands of Leyte, Samar, Cebu and Bohol, in addition to areas affected by the typhoon that followed the earthquake, to assist in assessing the state of damage to immovable and movable properties and intangible cultural heritage.

4-1 | Northern Luzon (Cagayan area)

| Magapit Shell-midden

The Magapit Shell-midden Site is a remains representative of the late Neolithic, located in the barangay of Magapit in the municipal of Lal-lo, Cagayan Province, in the northern part of Luzon Island. It is found on the western hills and along the west slope of a limestone hill that stretches west from the Sierra Madre Mountain Range, which runs north-south along the eastern coast of Luzon.

The Magapit Shell-midden Site was discovered by chance in 1971 by I. Cabanilla, who was then a researcher affiliated with the National Museum of the Philippines, and Yoji Aoyagi, from Sophia University who had been studying in the Philippines at the time. A test excavation was conducted in the following year, but the digging at the top of the hill did not reach the bedrock. Thereafter, explorations were conducted a number of times in 1977 and in the mid-1980s, followed by an excavation in 1987 by Yoji Aoyagi, then a professor at the Institute of Asian Cultures, Sophia University, Melchor L. Aguilera Jr., a researcher at the National Museum of the Philippines, Hidefumi Ogawa, an international student at Ateneo de Manila University, and Kazuhiko Tanaka, who was enrolled in a doctoral program at Sophia University at the time. The excavation at the top of the hill was conducted over a period of around two months by creating an excavation pit measuring 4 meters × 4 meters, and revealed that the deposit of shells was as thick as 5 meters and 60 centimeters. As many as 21,000 pottery fragments were unearthed from the deposit. Among the pieces of pottery that were unearthed, there were those that displayed pattern decorations. Those with puncture holes were particularly prominent, and displayed similarities with pottery pieces found in the Mariana Islands in the Pacific Ocean, including puncture holes with a saw-tooth appearance and puncture holes filled with lime. They captured the interest of researchers of Pacific Island prehistory, including P. Bellwood of Australian National University, who even discussed them in his general work titled *Prehistory of the Indo-Malaysian Archipelago*.

In addition to pottery pieces, the 1987 excavation of the top of the hill produced a variety of what appear to be stone implements, including 23 polished quadrangular stone adze fragments, 2 polished stone chisel fragments, 4 flakes and 1 grinding stone/hammer stone; clay items, including 5 clay disks, 1 spindle whorl and 38 pendants (28 were slitted); stone items, including 2 beads and a piece of slitted earring; and bone items, including 4 accessory fragments. Additionally, C14 dating yielded a value of 2800±140 B.P. from a piece of charcoal unearthed from the second layer (spit 9) and a value of 2760±125 B.P. from a piece of charcoal unearthed from the third layer (spit 20).

At present, the landowner's house stands at the bottom of the hill ascent to the shell midden site. Furthermore, despite the fact that the shell midden is an important remains not only within the prehistory of the Philippines but also the prehistory of the entire Pacific region, there are no signs indicating that the site is an archaeological site. There is nothing to indicate the boundaries of the site, either, and the site is rampant with weeds as matters stand. It will be necessary to install signs and cut underbrush within the boundaries of the site.

Reference

- Aoyagi, Y., Aguilera, M., Ogawa, H. and K. Tanaka 1988 Excavations at the Lal-lo Shell-middens. *The Journal of Sophia Asian Studies* 6: 63-104. (in Japanese).
- Aoyagi, Y., Aguilera, M., Ogawa, H. and K. Tanaka 1988 Excavations at the Lal-lo Shell-middens(3). *The Journal of Sophia Asian Studies* 9: 49-137. (in Japanese with English summary).
- Tanaka, K. 1999 Lal-lo Shell-middens, Philippines -Excavation of a huge shell-middens. *Archaeology Quarterly* 66: 75-78. (in Japanese).
- Bellwood, P. 1997 *Prehistory of the Indo-Malaysian Archipelago*. Revised edition. University of Hawaii Press. Honolulu.



Fig.9 Entrance of Lal-lo, Cagayan in Northern Luzon



Fig.10 House at the starting point of the Magapit Shell-midden



Fig.11 Hill to the starting point of the Magapit Shell-midden



Fig.12 Landowner of the excavation point of the Magapit Shell-midden and National Museum archaeology division researcher Ame M. Garong



Fig.13 Magapit Shell-midden: 1987 excavation point



Fig.14 View from the hilltop of Magapit Shell-midden

Lal-lo Church

Lal-lo is a town in Cagayan Province in the northern part of Luzon Island, on the east bank of the Cagayan River some 20 kilometers upstream of the mouth of the river. In the beginning of the Spanish era, it was named Nueva Segovia by Juan Pablo Carrion, who visited the city in 1592, and thereafter served as the center of Spanish rule in northern Luzon through the early years of the Spanish era.

Lal-lo Church was founded on August 14, 1595 by order of Pope Clement VIII, and functioned as the Diocese until the Diocese was transferred to Vigan in northwestern Luzon in 1755. It stands on a natural levee on the east bank of the Cagayan River, facing the river, indicating that the Cagayan River was a major traffic route in those times. The building is made of brick, with stucco used in some places, and has a connecting bell tower that houses a bell. The original ceiling of the church, however, has unfortunately been lost, and has been substituted with galvanized steel plates. The original ceiling may have been made of wood, but a close investigation of Spanish era documents needs to be made in the future, with an eye to restoring its initial appearance. As another major issue to be addressed in the future, it is necessary to get material evidences that provide direct reference to the history of Lal-lo before and after construction of the church by conducting an archaeological excavation in the vicinity of the church building, and an important focus of future research lies in identifying the location and kiln where the bricks used to build the church were fired.

Fort Lal-lo

Fort Lal-lo is the ruins of a Spanish era fort found in the village of Lal-lo Centro in the center of Lal-lo Town in Cagayan Province in Northern Luzon.

In the mid-1980s, when a battle broke out in and around the village of Fabrica on the west bank of the Cagayan River between the Philippine Army and the rebel New People's Army (NPA), the residents of Fabrica fled the battle and sought refuge in Lal-lo Centro. They made Lal-lo Centro their home and have continued to live in the village to this day. Part of the brick wall that is believed to be the wall of the fort still remains, but is now being used as the wall of an evacuee's home. After the Compañia General de Tabacos de Filipinas was established in 1881, the village is said to have been home to many factories and warehouses as the center of one of a number of tobacco production districts in the region.

As a future issue, a measurement research of the remaining part of what is believed to be the wall of the fort or other research should be conducted to the extent possible.

Reference

Castillet, Ed de Rivera 1960 *Cagayan Province and Her People*. Community Publishers, Inc. Manila.
Office of the Governor, Province of Cagayan (ed.) 1970 *Cagayan Almanac*.



Fig.15 Façade of Lal-lo Church, in Lal-lo, Cagayan in Northern Luzon



Fig.16 Inner view of Lal-lo Church



Fig.17 View from Lal-lo Church



Fig.18 Surrounding area of the wall of Fort Lal-lo in Lal-lo, Cagayan



Fig.19 Wall of Fort Lal-lo



Fig.20 Wall of Fort Lal-lo

| Camalaniugan Church

Camalaniugan is a town located on the east bank of the Cagayan River, around 12.5 kilometers upstream of the mouth of the river. It is a key traffic junction where the road leading to the town of Aparri at the mouth of the Cagayan River and the road leading to the town of San Vicente in the northeastern end of Cagayan Province meet. A ferry across the Cagayan River connects Camalaniugan with the west bank of the river.

Camalaniugan Church was founded in 1595. The bell tower next to it was built separately, and houses four bronze bells, among which the Santa Maria Bell, cast in 1595, is known as the oldest bell in the Philippines. The other three bells are the San Jacinto Bell, cast in 1792, the Nuestra Señora de Nieva y Santa Barbara Bell, cast in 1822, and the Santiago Apostol Bell, cast in 1879.

In its present state, the staircase inside the bell tower is narrow and difficult to climb. Additionally, because the bells are exposed to the outdoor environment, they are covered with green rust, and since no information boards about the bells are provided, it is difficult to identify which of the four is the Santa Maria Bell, the oldest bell in the Philippines.

In the future, a measuring research and chemical analysis of the materials of these bells would need to be made.

Significant results could be expected from chemical analysis of the materials, since it has been recently identified that the Song Toh Mine in western Thailand supplied lead to Southeast Asia and East Asia in the 15th and 16th centuries, making it possible to identify the production areas of lead contained in bronze.

Moreover, since the casting dates of the bells are known, any progress in the measuring research would likely produce useful typological research material.

Reference

- Hirao, Y., Yamaguchi, S. and W. Worakanok 2012 Lead of the Song Toh Mine in Thailand. in Hirao, Y. (ed.) *Historical Study of the metal trade in the East Asian using the lead isotope percentage analysis –Report of the Japanese science research grant for the new academic area (No.21200028)*.
 Castillet, Ed de Rivera 1960 *Cagayan Province and Her People*. Community Publishers, Inc. Manila.
 Office of the Governor, Province of Cagayan (ed.) 1970 *Cagayan Almanac*.



Fig.21 Bell in belfry of Camalaniugan Church, Cagayan



Fig.22 Belfry of Camalaniugan Church



Fig.23 Inner view of belfry roof

Callao Cave

Callao Cave has attracted attention in recent years as an archaeological site where the oldest human bone in the Philippines dating from 67,000 years ago has been found.

The cave is located within a limestone area in the barangay of Quibal in Peñablanca, about 12 kilometers in direct distance northeast of Tuguegarao, the capital of Cagayan Province in the northern area of Luzon Island. The Pinacanuwan de Tuguegarao River flows from the Sierra Madre Mountain, with the south end of the northern limestone zone forming a sheer cliff facing the river. Callao Cave is one of many caves made in this cliff. It has an opening that is 15 meters wide, and the first chamber inside the opening is more than 22.5 meters deep. It is the largest among such caves in the limestone formation, which is made up of a multiple number of similar chambers inside.

Archaeological excavation of Callao Cave have been conducted in 1979, 2003 and 2007, and the 2007 excavation yielded a human bone that has been dated as the oldest human bone found in the Philippines. In the excavation conducted in 1979 by Noel Cuevas of the National Museum of the Philippines, an area measuring 4 meters × 4 meters was excavated on the west side of the cave entrance (Cuevas 1980), and a burial containing a celadon bowl of the Ming dynasty was discovered. However, no occupational layers dating back to the Pleistocene were found. Thereafter in the 2003 survey led by Armando Mijares of the Archaeological Studies Program at the University of the Philippines, two excavation pits measuring 2 meters × 2 meters were dug. As a result, chert flakes, burnt animal bones and the remains of a hearth have been found in a layer 130 centimeters below the ground surface, with a date of $25,968 \pm 374$ B.P. (Mijares 2010:2). Based on the results of the 2003 excavation, the third metatarsal of a human foot was found, with a dating of $66,700 \pm 1,000$ B.P. (Mijares 2010:2.6). Judging by the result of the dating, the bone was identified as the oldest human bone found in the Philippines.

Meanwhile, the excavation pits dug by Mijares near the entrance on the east side of the cave opening were left without backfilling them and surrounded with an iron fence. A plastic sheet attached to the outside of the fence serves as an explanatory board, with descriptions of the excavation findings printed in English on a white background along with photos and diagrams, which is a creative idea. Inside the cave, an altar dedicated to the Blessed Virgin Mary has been created in the central wall of the chamber, and pews have been installed facing the altar, so that church services can be held.

The cave is reached by climbing a long flight of concrete stairs up to the opening. At the bottom of the stairs is a road, and slightly in front of the road on the west side is a parking lot. Outside the parking lot, there are stalls selling refreshments such as banana cues, T-shirts and other such gifts and souvenirs, and past these stalls is the admission booth, consisting simply of an ecotourism sign and a desk. An admission of 20 pesos per person is collected by Peñablanca city. On weekdays, around 100 to 500 people visit the cave on a busy day and 50 to 100 on a slow day, while on the weekends, some 500 to 1000 people come to visit. Visitors can also take the ferry that crosses from the village of Baggaba on the opposite shore to the Callao side and travel upstream to view the limestone area from the river. Further utilization of the ferry could perhaps be found through cooperation with the village.

Reference

Cuevas, M., n.d. Preliminary Report on the Archaeological Excavation conducted at Callao Caves. Manuscript of the National Museum of the Philippines, Manila.

Mijares, A. et al., 2010 New evidence for a 67,000-year-old human presence at Callao Cave, Luzon, Philippines. *Journal of Human Evolution* 30: 1-10.



Fig.24 Tollbooth at starting point of Callao Cave



Fig.25 Entrance of Callao Cave



Fig.26 Excavation point of Callao Cave



Fig.27 Excavation trench of Callao Cave



Fig.28 Excavation area of Callao Cave



Fig.29 Chapel inside Callao Cave

| Atulu

Atulu is a pottery-making village located in the town of Iguig in Cagayan Province in the northern region of Luzon Island. It is one of the few barangays in the province that still produce earthenware pottery to this day, along with Quinagabian in the town of Santa Maria in Isabela Province. Studies are made of pottery production in Atulu, because most of the artisans in the village still make clay products using the traditional paddle and anvil technique instead of a potter's wheel. The paddle and anvil technique of producing pottery is said to have originated in prehistoric times and been passed down seamlessly through generations. For this reason, gaining an understanding of pottery making in Atulu is considered a helpful hint for gaining an understanding of prehistoric pottery in the region.

Pottery-making in Atulu was probably first studied by D. Scheans of Portland State University, who conducted a study from 1968 to 1969 as part of a larger research project to compile a general work on pottery-making in the Philippines as a whole. In his study, Scheans reported on the types of vessels that were made, the names of parts of pottery, gender roles, types of tools, the production process and selling methods (Scheans 1977). Thereafter, Yoji Aoyagi of Sophia University conducted a study of the production process of cooking pots and flower pots in the village in 1977 (Aoyagi 1980, Aoyagi and Okazaki 1981). This writer also conducted a study of pottery making in Quinagabian in the town of Santa Maria in Isabela Province in 1993 (Tanaka 1998) along with a study of pottery making in Atulu, and pointed out, based on a comparison of pottery making in the two villages, that there are differences in the main types of vessels produced in the two villages (Tanaka 1998). The writer then conducted a study in 2011 and 2012 with Ame Garong of the National Museum of the Philippines to analyze the changes in pottery making from the previous study (1993), and found changes in the source of clay, a decline in the production of cooking pots, partial changes in pottery-making tools, and changes in production technique among the young generation of artisans (the paddle and anvil technique was no longer conveyed) (Tanaka, Garong and Ronquillo 2012; Tanaka 1993a, b). The eventual dissemination of mold making using plastic molds among the young generation in their 20s has greatly changed the pottery-making scene in the village, and has raised concerns about the inevitable discontinuation of pottery making using the paddle and anvil technique, which continued to be used in the region since the Neolithic Age. There is thus an urgent need to study the paddle and anvil technique of pottery making, and based on this awareness, a study is presently being made mainly of the tools used in the technique, with plans to continue the study through this year.

Reference

- Aoyagi, Y. 1980 The pottery making in northern Luzon –a case study of Atulu. The Society of the Black Current Cultures (ed.) *Ethnic Groups, cultures and languages of the Black Current Area*. Kadokawa Bookstore: 88-104. (in Japanese).
- Aoyagi, Y. and Okazaki, K. 1981 Open firing of the pottery –Paddle and anvil method in Luzon-. *Ethnology Quarterly* 15: 53-57. (in Japanese).
- Tanaka, K. 1998 Pottery Making in Barangay Quinagabian, Santa Maria in the Middle Reaches of the Cagayan River, Northern Luzon. *Journal of Environmental Studies* 6 :123-152. (in Japanese with English summary).
- Tanaka, K. 2013a Persistence and changes of the tools for pottery making –a case study in northern Luzon-. *Material Culture -Journal of Archaeologico-Folkloric Studies-* 93: 49-72. (in Japanese with English summary).
- Tanaka, K. 2013b Pottery Stove Making in Atulu, Northern Luzon. *Bulletin of the Yokohama Museum of EurAsian Cultures* 1: 63-74. (in Japanese with English summary).
- Scheans, D. 1977 *Filipino Market Pottery*. National Museum Monograph No.3, Manila.
- Tanaka, K., Garong, A. and Ronquillo W. 2012 A comparative study of the pottery making in Atulu, Northern Luzon between 1993 and 2011 or 2012. *Journal of Southeast Asian Archaeology* No.32. pp.99-104



Fig.30 Atulu



Fig.31 Pottery-making family in Atulu



Fig.32 Pottery in Atulu



Fig.33 Pottery in Atulu



Fig.34 Pottery atelier in Atulu



Fig.35 Firing place for pottery in Atulu

4-2 | Northern Luzon (Vigan area)

| Santa Maria Church

Santa Maria Church, or the Asunta Parish church is a national landmark that was used as a fortress during the 1896 Revolution. It is located in Ilocos Sur. It was declared a world heritage site by UNESCO on December 11, 1993. Built around 1765 by the Augustinians, the church also functioned as a citadel during the Spanish era. The church is situated on the top of a hill and is reached by climbing 85 steps of granite rocks that were imported from China. Thick buttresses on each side function as an earthquake-resistant construction. The architecture of the church is inspired by the Baroque style.

| Santa Lucia Church

Indigenous people resided in Narcavan before the Spanish established a township in 1576. The Augustinians established the parish in 1587. The date of the current building is not determined.

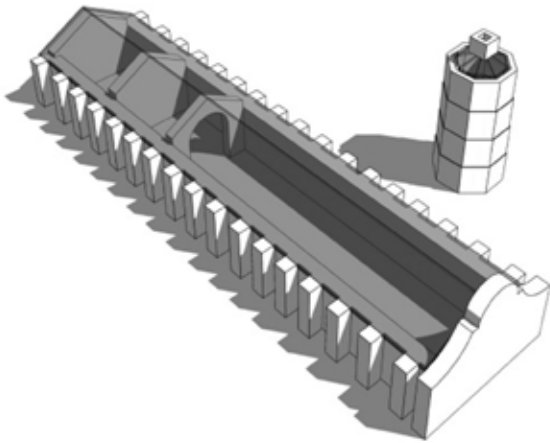

Fig.36 Perspective drawing of Santa Maria Church



Fig.37 Front steps of Santa Maria Church



Fig.38 Façade of Santa Maria Church

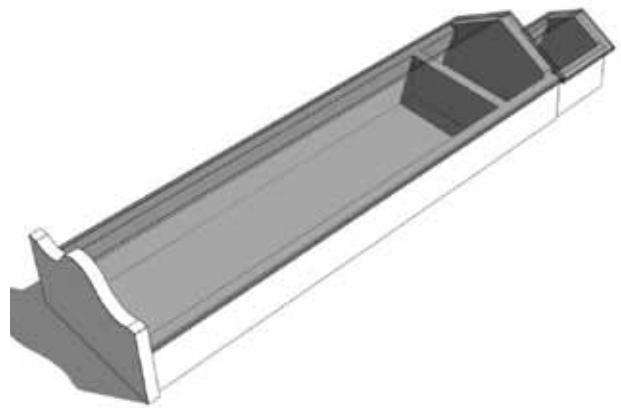

Fig.39 Perspective drawing of Santa Lucia Church



Fig.40 Façade of Santa Lucia Church



Fig.41 Inner view of Santa Lucia Church

| Vigan city

Vigan was a coastal trading post with South China before the Spaniards arrived. The city was established by the Spanish in the 16th century (around 1572) for defense against the neighboring countries.

In 2007, Vigan City was listed as a world heritage site by UNESCO as the best preserved example of a Spanish colonial town in Asia. Its architecture is a conglomeration of cultural elements from the Philippines, China, and Spain, making it unique in the world.

| San Agustin Church

The construction of the church was begun in 1694 by the Augustinian Antonio Estavillo, and was completed in 1710. Paoay, where the church is located, became an independent Augustinian parish in 1686.

In 1993, the church was designated as a UNESCO World Heritage site as one of the best examples of the Baroque churches of the Philippines. The San Agustin Church is a prime example of earthquake-resistant Baroque architecture, which is the Philippine interpretation of the European Baroque adapted to the seismic conditions of the country.



Fig.42 Townscape of Vigan City



Fig.43 Traditional "Bahay na bato" house



Fig.44 Interview with the City Mayor of Vigan



Fig.45 Façade of San Agustin Church (taken by Juan, in August 2012)



Fig.46 Buttress of San Agustin Church (taken by Juan, in August 2012)



Fig.47 Vegetation on outer wall of San Agustin Church (taken by Juan, in August 2012)

4-3 | Central Luzon (Manila and Angono)

| National Archives

The National Archives was created in 1898, when the sovereignty shifted from Spain to the United States of America, under the American Authority which stipulated the documents of relinquishment or cession, to provide for the preservation of documents in Spain and the Philippines.

The collection is organized into two groups: the Spanish era Documents (1552–1900) and the American and Republic Period Documents.

| National Library

The National Library of the Philippines was established by the Spanish government in 1887 and was opened in 1891 at the Casa de la Moneda in Intramuros. The current National Library building is located in Rizal Park, a six story building constructed in 1961. The collections of the National Library of the Philippines consist of more than 210,000 books, over 880,000 manuscripts, more than 170,000 newspapers, 66,000 theses and dissertations, 104,000 government publications, 3,800 maps and 53,000 photographs. The library's collections include large numbers of materials stored in various forms of non-print media, as well as almost 18,000 pieces for use of the Library for the Blind Division.



Fig.48 External view of National Archives



Fig.49 Document preservation laboratory of the National Archives



Fig.50 Document preservation laboratory of the National Library



Fig.51 Interview with the staff of the National Library and commemorative photo

| National Museum

The National Museum of the Philippines is a repository and custodian for the country's natural and cultural heritage.

The museum "manages and develops national reference collections in areas of cultural heritage including fine arts, anthropology and archaeology, and natural history [botany, zoology, geology and paleontology] and carries out permanent research programs in biodiversity [flora and fauna], geological history, human origins, pre-historical and historical archaeology, maritime and underwater cultural heritage, ethnology and art history."¹

The museum organization is headed by the Office of the Director, under which there are twelve divisions related to research, education and science, and the Administrative Division, which reports immediately to the Director. The twelve divisions are: Archaeology, Anthropology, Geology, Botany, Zoology, Art, Cultural Property, Museum Educational, Planetarium, Chemistry and Conservation, Restoration and Engineering, and Archaeological Site and Branch Museum.

The museum is operated by the director, the National Museum Board of Trustees, which is composed of eleven trustees and a chairman of the board, and thirteen division heads. The director is appointed by the president.

In the museum complex, on the second floor, there is an exhibition room dedicated to a collection of small works of art by Juan Luna and an exhibition room that displays a collection of wooden sculptures from the Spanish era. Meanwhile, the third floor has an exhibition room for the Zooarchaeology Subdivision, but many of the rooms are still under renovation. The fourth floor houses staff offices for each of the divisions, as well as a room for the Archaeological Records Subdivision, which conserves and manages various archaeological records. On the opposite side of the front entrance on the ground floor is a storage room of archaeological materials. The ground floor entrance opens out onto a display of a ship replica modeled on a ship from the Age of Contact discovered in the Balangay Site in Butuan City, located downstream on the Agusan River in the northeastern part of Mindanao Island.

Across the street from the National Gallery is the Museum of the Filipino People. On the first floor is a display of the San Diego, a ship that was engaged in a battle and sunk by a Dutch battleship, just off Manila Bay in 1600 during the Spanish era. The display recreates the scene of the sunken ship on the seafloor, with the ship's hull on a bed of sand along with various artifacts that have been discovered. On the second floor, an exhibition room is dedicated to artifacts retrieved from the San Diego, and another exhibition room is dedicated to artifacts discovered from five sunken ships that provide evidence of active trading that continued over five centuries between the Philippines and China or countries in continental Southeast Asia before the arrival of the Spanish. On the third floor, an exhibition room provides a diachronic display of archaeological materials from the Paleolithic Period to the Age of Contact, another exhibition room features unique human-shaped burial jars discovered from Ayub Cave in Sarangani Province in the southwestern part of Mindanao Island, while another exhibition room showcases ethnic materials. The central area of the triangular building is an inner courtyard featuring an outdoor display of a raised house of the Ifugao, mountain tribes in the northern part of Luzon Island.

As described above, the National Museum of the Philippines offers a wealth of important exhibits in a number of exhibition halls, but also has several problems. For instance, the museum's pamphlets are constantly out of stock; there are no catalogues of permanent exhibitions; it is difficult to know the state of exhibits inside exhibition rooms particularly in the annex museum, because the rooms are kept closed by thick doors to maintain the efficiency of air conditioning systems; and there are too few signs in town indicating the museum's location.

¹ *Annual Report 2011*, National Museum of the Philippines: 7.



Fig.52 External view of National Museum



Fig.53 Exhibition at National Museum



Fig.54 Exhibition of the San Diego Shipwreck Site



Fig.55 Outdoor exhibition at Ifugao house



Fig.56 Interview with Curator II of Archaeology Division

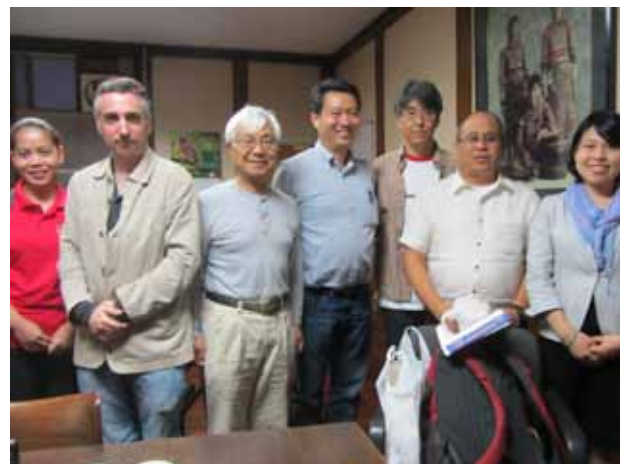

Fig.57 Interview with Chief of Cultural Properties Division and commemorative photo

| Casa Manila Museum

Intramuros is the oldest district in Manila, and is also valuable in terms of history. During the Spanish era (1590–1872), a fort was constructed to protect the city from foreign invasions. However, it was damaged severely during World War II. It has been under repair from 1951 to today. In the district stands Fort Santiago, Manila Cathedral, many churches and monasteries, educational institutions (university and schools), and government office buildings.

The Casa Manila Museum in Intramuros exhibits the lifestyle of the Spanish era. The architecture is a restoration of the San Nicolas House (1850). It was constructed in 1980 by Imelda Marcos (widow of former Philippine President Ferdinand Marcos).

| San Agustin Church

San Agustin Church was designed by Juan Macias, and was constructed during 1586 to 1607. It was destroyed by the British invasion in 1762, but it was restored in 1854 under the supervision of Luciano Oliver. The left belfry collapsed by an earthquake in 1880, though it had escaped destruction by the earthquakes in 1645, 1699, 1754, and 1852. During the Japanese occupation in World War II, the church was used as a concentration camp for prisoners. In 1945, during the United States invasion, the church escaped destruction, but the monastery collapsed. The monastery was reconstructed in 1970, and was opened to the public as a museum. In 2013, the stone used in the façade were changed to the same color as the original construction. San Agustin Church was listed on the UNESCO World Heritage List in 1993.



Fig.58 External view of Casa Manila Museum



Fig.59 Entrance of Casa Manila Museum



Fig.60 Façade of San Agustin Church



Fig.61 Inner view of San Agustin Church



Fig.62 Appearance of San Agustin Church after World War I

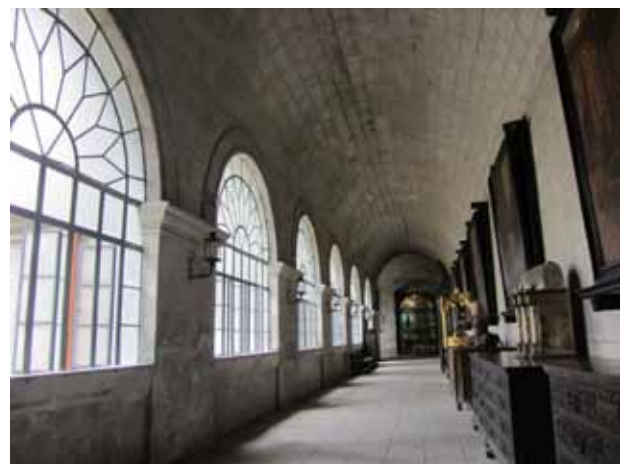

Fig.63 Sacred utensils displayed inside San Agustin Church

| Basilica Minore de San Sebastián

Basilica Minore de San Sebastián is the only all-steel church or basilica in Asia, and the only prefabricated steel church in the world, built in 1891. The original church, made of wood, burned in 1651 during the Chinese uprising. It was reconstructed of brick, but was destroyed by fire and earthquakes in 1859, 1863, and 1880.

In the 1880s, a Spanish architect, Genaro Palacios, designed the plan to build a fire- and earthquake-resistant structure made entirely of steel. The final design was inspired by the Gothic Cathedral of Burgos in Spain.

The prefabricated steel sections were manufactured in Binche, Belgium. 52 tons of prefabricated steel sections were transported in eight separate shipments from Belgium to the Philippines. The stained glass windows were imported from Germany. Gustave Eiffel was involved in the design and construction of San Sebastian Church.

In 2006, Basilica Minore de San Sebastián was included in the Tentative List for possible designation as a World Heritage site. It was designated as a National Historical Landmark by the Philippine government in 1973. Near Manila Bay, the steel structure has been damaged by rust and corrosion.

| Shop houses in Binondo (China Town)

Binondo is located across the Pasig River from Intramuros in Manila. Established in 1594, it is considered the oldest Chinatown in the world. Currently the district of Binondo is the center of commerce and trade for all types of businesses run by Filipino-Chinese merchants. During the 18th and 19th century, under the influence of China, a new type of building named Accesoría appeared throughout the Philippines. Accesorías are two story, detached shop house buildings. Currently there are few buildings, and these are occupied by low-income families. The buildings are in very bad state of preservation, and there is no social awareness program for the conservation of these 19th century buildings.



Fig.64 External view of Basilica Minore de San Sebastian



Fig.65 Inner view of Basilica Minore de San Sebastian



Fig.66 Steel-frame roof of Basilica Minore de San Sebastian



Fig.67 Shop houses in Binondo (China Town)



Fig.68 Shop houses in Binondo (China Town)



Fig.69 Shop houses in Binondo (China Town)

| Angono Site

The Angono Petroglyphs site is located in the town of Angono near the boundary with Binangonan, approximately 25 kilometers east of Manila on Luzon Island. It is situated in the hills composing the western edge of the Sierra Madre Mountain Range, which runs north-south along the eastern coast of Luzon, from the northern to central part of the island. There is a metal plate on the left side of the entrance to the man-made tunnel leading to the site, and the area in front of the plate is used as parking space. A security guard stands at the entrance to the tunnel to guide visitors.

On one side of the site is a small branch museum of the National Museum of the Philippines. Although it has one exhibition room only, it displays panels in English that introduce the history from the discovery of the petroglyphs to their research and research findings. The museum showcases stone implements and fossil bones of Pleistocene animals discovered from other archaeological sites in the same province of Rizal as the Angono site. In association with the line drawings, the museum also exhibits items that include written materials excavated in the Philippines; an inscribed copper plate (replica; 10th century) discovered in Laguna Province; an inscribed pottery fragment (replica) discovered in the Intramuros, a walled city of a Spanish community that developed in Manila during the Spanish era; and an inscribed rock (replica) discovered on Ticao Island in the Bicol region in southern Luzon.

The rock shelter with the petroglyphs is found at the top of a gentle slope to the right of the museum, and is composed of Quaternary tuff, which was formed by a fault according to the display. The rock shelter is 63 meters wide, 8 meters deep and 5 meters high. The petroglyphs are found in an area 25 meters wide and 3 meters high, and include a total of 127 line drawings of what appear to be human and animal figures. As 51 figures among them were identified as distinct drawings, it is believed that the petroglyphs were drawn by a multiple number of individuals. It is also believed that fine-textured flake tools were used to carve the drawings on the relatively soft rock wall.

To verify the above assumptions, an archaeological excavation was conducted from October to November 1965, in an area measuring 4 meters by 5 meters. As a result, two pieces of pottery fragments and two chert chips were excavated, and the site came to be regarded as dating from before the introduction of metal tools, namely the Neolithic Age (at least from the first millennium B.C.). In response to these excavation results, the Angono Petroglyphs were recognized as the oldest work of art in the Philippines and designated a National Cultural Treasure by Executive Order No. 260 of August 1973. Furthermore, in 1985, they were included in the World Inventory of Rock Art along with other famous prehistoric wall paintings, under the auspices of UNESCO, ICOM, ICOMOS and ICROM.

According to Mr. Roden T. Santiago, a staff member of the archaeological museum, before the tunnel was built in 1996, it could only be reached after walking more than 2 kilometers from the main road and climbing down a staircase of more than 100 steps. Similarly, until 1994, the wooden visitors' viewing deck that exists today did not exist, and there were times when the site suffered intentional damage. Today, the site receives some 1,500 visitors per day, although there are some fluctuations depending on the month, and received some 800 foreign visitors in 2012. While explaining the above, Mr. Santiago pointed out a Philippine Eagle Owl (*Buho dilepensis*) perched on a tree in front of the petroglyphs. This not only provided a realization of the significance of the remaining forest around the rock shelter, but also an awareness that the forest provides an important tourism resource that offers a glimpse into the living environment of the people who drew the petroglyphs.



Fig.70 Entrance of tunnel to the Petroglyphs of Angono Site



Fig.71 Signboard of entrance of the Petroglyphs of Angono Site



Fig.72 Exhibition hall in front of the Petroglyphs of Angono Site



Fig.73 Viewing deck of the Petroglyphs of Angono Site



Fig.74 Viewing deck of the Petroglyphs of Angono Site



Fig.75 Location of an excavation trench of a rockshelter in the Angono Site

4-4 | Cebu

| Casa Gorordo (Museum)

The house was built in the 1850s and was originally owned by Alejandro Reynes y Rosales. It was bought by Juan Isidro Gorordo, a Spanish merchant, in 1863. The first floor was built of coral stone, the second floor of molave (tugas) wood, and the roof with clay tiles. It has wide windows with sliding panels of capiz shells. The Gorordo house was renovated between 1980 and 1981, and was opened to the public in 1983 as a 19th century lifestyle museum (a project of the Cultural Heritage Program of the Ramon Aboitiz Foundation, Inc.).

| Jesuit House of 1730

Located in the Parian district of Cebu City, this is one of the oldest houses in the country today. It was built in 1730 and was once a residence of the Jesuit Superior in Cebu. After the Jesuits were eventually expelled from the Philippines in 1768, the Jesuit House had several other owners.

The house is composed of 2 structures, connected by a bridge. The main house is a two story building made of coral stones. The smaller building has a bipartite structure, consisting of a first floor made of cut coral stone, and a second floor made of wood. Its influence from the Chinese is evident from the original wooden structure of the roof and the terracotta tiles. Ceramics of the Ming dynasty were also found. The ground floor has been transformed by the current owner (Mr. Jaime Sy) into a Museum called Sugbo Gallery. The gallery is centered on the history of the Chinese Parian of Cebu.

Some tiles of the roofs have been affected by the earthquake, causing the infiltration of water into the exhibition spaces.



Fig.76 External view of Casa Gorordo (Museum)



Fig.77 Inner view of Casa Gorordo (Museum)



Fig.78 Window made of capiz shells



Fig.79 Entrance of Jesuit House made of coral-stone



Fig.80 Porcelain and china of Ming dynasty exhibited in Jesuit House



Fig.81 Clay-tile roof of Jesuit House

| Fort San Pedro

The fort was first made of wood by the Spanish and indigenous Cebuano laborers under the command of the Spanish conquistador, Miguel López de Legazpi. It is said that the coral stone fort was made between 1630 and 1739, but this remains uncertain. The fort is triangular in shape, with two sides facing the sea and the third to the land. The two sides facing the sea were defended with artillery and the front with a strong palisade made of wood. The total area inside the fort is 2,025 square meters. The walls are 6.1 meters high and 2.4 meters thick. Defense towers are 9.1 meters high from the ground level.

During the American colonization period, Fort San Pedro became part of the American warwick barracks. From 1937 to 1941, the barracks were used as school. During World War II, Japanese residents of the city took refuge within its walls. From 1946 to 1950, Fort San Pedro was an army camp. It was converted into a miniature garden after 1950. At present, it is under the care and administration of the City of Cebu, as a historical park. Part of the fort is a small museum.

State of Damage

The fort has been severely affected by the earthquake. The stone roof of La Concepcion bartizan, has fallen down. San Miguel bartizan has been completely demolished. Many stones have fallen off the walls outward. Some parapets have collapsed and stones have detached from the main façade. Currently It still remains open to the public although it is in a dangerous state.

| Basilica Minore del Santo Niño

The Basilica Minore del Santo Niño is the first church and monastery established in the Philippines. It is also a center of devotion which worships the oldest Christian image, of Jesus as an infant king.

The church is made of cut coral stones, which are said to have been quarried from Panay Island while wood was brought from Talisay (Cebu) and Pitalo (Cebu). The façade is a blend of Muslim, Romanesque and Neo-Classical structures. The church has a single three-story belfry attached to the northern end of the façade. At the south is a palatial two story monastery with a courtyard in the interior.

State of Damage

The earthquake destroyed the belfry but the rest of the church was not damaged.



Fig.82 External view of Fort San Pedro



Fig.83 Fort San Pedro after earthquake



Fig.84 Destroyed stone wall of Fort San Pedro after earthquake



Fig.85 External view of Basilica Minore del Santo Niño



Fig.86 External view of Basilica Minore del Santo Niño after earthquake



Fig.87 Collapsed belfry of Basilica Minore del Santo Niño after earthquake

| Cebu Metropolitan Cathedral

The Cathedral was constructed by Bishop Diego de Aguilar during 1680–1692. Most of the Cathedral was destroyed by the Allied bombings during World War II, including the belfry, the façade, and the remaining wall, which were built in 1835. However, they were quickly rebuilt after the war.

Its structural features are the following: a cruciform layout, a façade featuring a trefoil-shaped pediment decorated with carved reliefs of floral motifs, an IHS inscription, a shell symbolizing baptism, and a pair of griffins.

State of Damage

The earthquake has affected the main façade and the bell tower where large cracks have appeared.

| Church of San Francisco de Asís

The construction plan for the church was executed by Bishop Santos Gomez Marañon, and was built by Father Simon Aguirre in 1850. A stone-made parsonage was built by Father Enrique Magaz, who was the diocesan priest from 1857 to 1864. On November 25, 1876 a typhoon damaged the belfry and the restoration was carried out by Father Emiliano Diez in 1886. Towards the end of World War II, the church was damaged by American bombing raids and the belfry and the parsonage were totally destroyed. A different belfry was later built by Monsignor Cesar Alcosoba in 1979, while a new parsonage was built in the mid-1970s by Father Arturo Tecson.

The church is a single-nave cruciform structure that stands along the street facing the old municipal hall and town plaza. Most of the interior is already modern. The façade has motifs and symbols combining Islamic and Mexican influences, making it unique in Cebu. There is a total of five retables inside.

State of Damage

No serious damage after the earthquake.



Fig.88 External view of Cebu Metropolitan Cathedral



Fig.89 Crack in belfry of Cebu Metropolitan Cathedral after earthquake



Fig.90 Crack in façade of Cebu Metropolitan Cathedral after earthquake

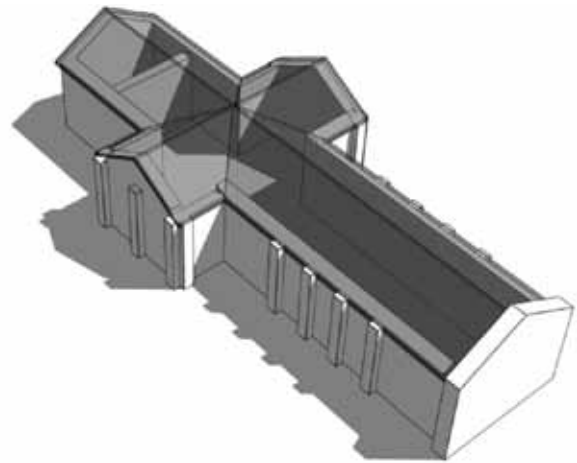

Fig.91 Perspective drawing of Church of San Francisco de Asís



Fig.92 External view of Church of San Francisco de Asís



Fig.93 Inner view of Church of San Francisco de Asís

| Church of Santa Catalina de Alejandria

Church of Santa Catalina de Alejandria was built by the Augustinians between 1860 and 1875. Construction was started by Father Antonio Manglano and was finished during the era of Father Fernandez Rubio. It is built with finely cut coral stones. It is a rectangular plan instead of the typical cruciform layout common to most churches. The interior of the chancel is Greco-Roman in style. The architecture of the church features various influences, particularly of Islamic style and the Greco-Roman style.

The church is located in Carcar, known as the heritage city of Cebu, because of its well-preserved Spanish and American colonial period houses and edifices.

State of Damage

No serious damage was seen after the earthquake.

| Church of Nuestra Señora del Pilar de Zaragoza

The construction of the church started between 1846 and 1868 and was completed during the era of Father Enrique Magaz in 1881. The church was restored in 1907. The houses in the diocese were built by Bishop Santos Gomez Marañon before 1839. The church features prewar ceiling frescoes that depict various biblical scenes. They were painted by the Cebuano artist Rey Francia, who also painted the frescos in other Spanish era churches in Bohol.

State of Damage

No serious damage was seen after the earthquake.

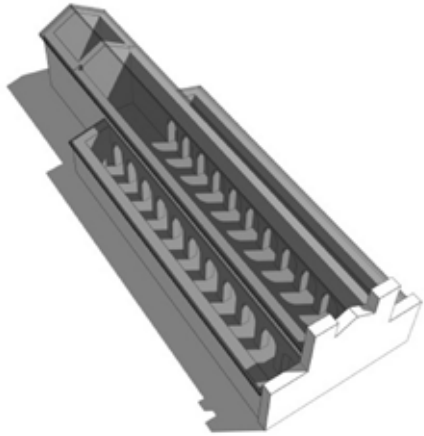

Fig.94 Perspective drawing of Church of Santa Catalina de Alejandria



Fig.95 External view of Church of Santa Catalina de Alejandria



Fig.96 Restoration of crack in the belfry of Church of Santa Catalina de Alejandria after earthquake

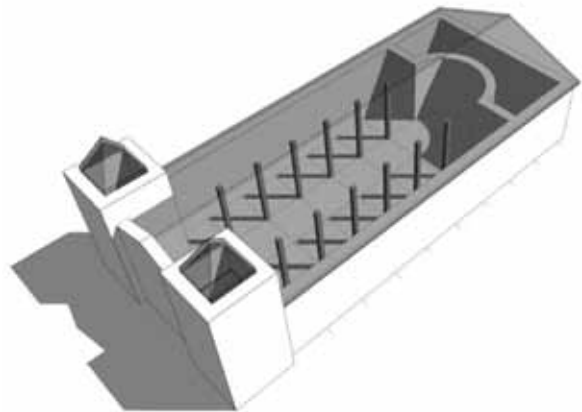

Fig.97 Perspective drawing of Church of Nuestra Señora del Pilar de Zaragoza



Fig.98 External view of Church of Nuestra Señora del Pilar de Zaragoza



Fig.99 Inner view of Church of Nuestra Señora del Pilar de Zaragoza

Church of San Miguel el Arcángel

Church of San Miguel el Arcángel was built in 1783 by Father Francisco Espina.

The church complex is surrounded by a stone fence with three gates. The eastern gate that opens to the sea also functions as a watchtower, with a narrow staircase leading to the top. Beside the gate is a mortuary. Each corner has a capilla posa (small chapels or shrines for the worshippers to stop by during a procession, common in Spanish colonial churches in Mexico). There are two governmental buildings (the Argao Hall of Justice and the old municipal hall) along with the church and some other Spanish era structures.

State of Damage

There is earthquake damage to the main façade and belfry.

Church of San Guillermo de Aquitania

Construction of the church began in 1802 and finished in 1825. The church has a simple façade which is divided horizontally into three sections. There is a free-standing belfry that was built separately between 1850 and 1860.

State of Damage

There is severe structural damage to the main façade and belfry. The roof of the sacristy collapsed due to falling stones.

Church of Patrocinio de Maria

The original church was built in the 17th century but was destroyed by fire. The present-day church was built in 1783. Father Julian Bermejo fortified the church complex with stone walls. An armed bulwark, which is currently being used as a belfry, was also built at the southeast portion of the fortification, and a watchtower on a hill in the north. The church is connected to an L-shaped convent. A museum currently occupies the ground floor. The church roof has the original clay tiles. The Boljoon Church is a National Heritage Landmark and is currently undergoing restoration. It is included on the list of 26 National Cultural Treasures by the National Museum of the Philippines, and has also been nominated for inclusion on the UNESCO list of World Heritage Sites.

State of Damage

No serious damage was seen after the earthquake, although there are cracks on the stone walls and buttresses.

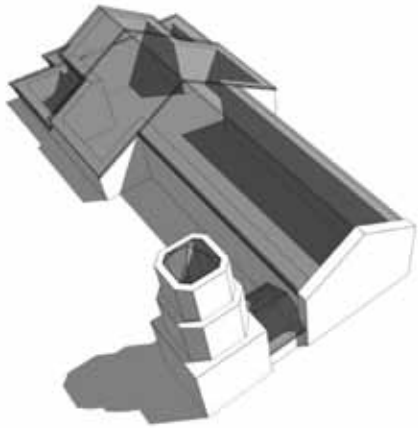

Fig.100 Perspective drawing of Church of San Miguel el Arcángel



Fig.101 Vegetation on exterior on Church of San Miguel el Arcángel

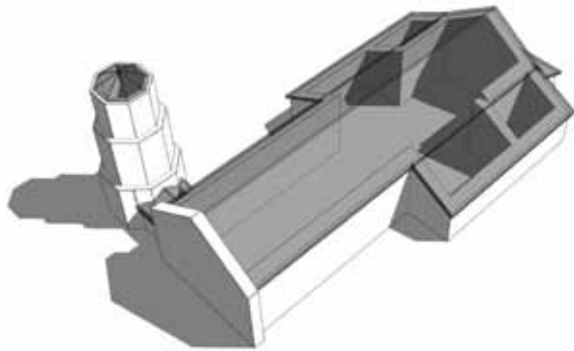

Fig.102 Perspective drawing of Church of San Guillermo de Aquitania



Fig.103 External view of San Guillermo de Aquitania

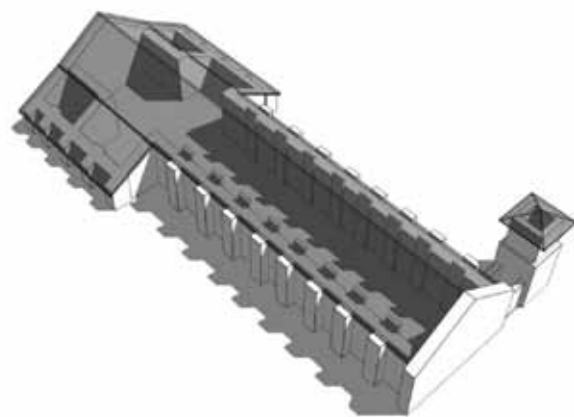

Fig.104 Perspective drawing of Church of Patrocinio de Maria



Fig.105 External view of Church of Patrocinio de Maria

Church of Inmaculada Concepcion

The church was built by Father Julian Bermejo between 1830 and 1848, following the plans of Bishop Santos Gomes Marañon. It was built with cut coral stones. The church was destroyed by fire in 1942 and after the restoration, it burned again in 1955, and the monastery also burned in 2008. The church was eventually restored in recent years. The entire church complex is surrounded by a stone fence. At the southeast are remains of military barracks. Outside the walls are the remains of a watchtower.

State of Damage

No serious damage after the earthquake.

Museo Cebu (Museo Sugbo)

The Carcel de Cebu was designed in 1869 by Domingo de Escondrilla (19th century architect in Cebu) and was built in 1871. It has been used mainly as a penitentiary by the Spanish, the Japanese and the Americans – and continued so under the Filipino influence. In 2004, the conversion of Carcel de Cebu into the Museo Sugbo, a repository of Cebuano heritage, started. The first four galleries of the museum were opened in 2008. There are total of 10 galleries. All rooms are air-conditioned, and thoroughly protected by security.

State of Damage

No serious damage was seen after the earthquake.

Cathedral Museum of Cebu

The Cathedral Museum of Cebu is a permanent repository of the tangible treasures of the archdiocese of Cebu. The two story building was originally used as the cathedral parsonage in the 19th century. The second floor rooms have an old-fashioned atmosphere, with capiz shell windows that take in natural light. these windows present security issues, and there are problems with rainwater drainage.

State of Damage

No serious damage was seen after the earthquake.

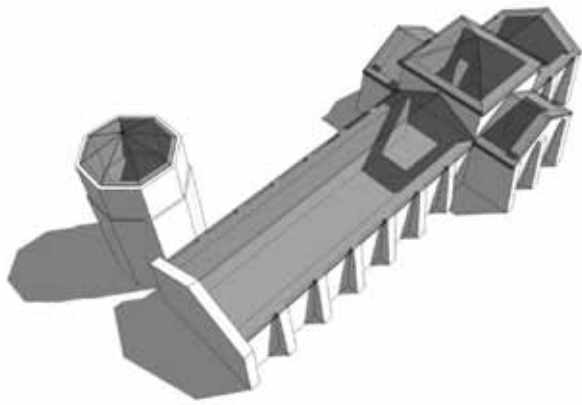

Fig.106 Perspective drawing of Church of Inmaculada Concepcion



Fig.107 External view of Church of Inmaculada Concepcion



Fig.108 Courtyard of Museo Cebu (Museo Sugbo)



Fig.109 Exhibition of Museo Cebu (Museo Sugbo)



Fig.110 External view of Cathedral Museum of Cebu



Fig.111 Exhibition of Cathedral Museum of Cebu

4-5 | Bohol

| Church of Isidore the Farmer

Tubigon was a stronghold of the Jesuits in 1613. The church was built by the Recollets in 1886. The church is constructed in a basilical plan with a central nave, aisles and an octagonal cupola. It was built with coral stone at first.

These new materials were used during 1928 to 1934, when the bell tower was constructed. The nave is covered with a ceiling decorated in metal, designed by Ray Francia.

State of Damage

The church has been badly damaged by the earthquake.

| Church of Nuestra Señora de la Luz

The Church of Nuestra Señora de la Luz built in 1853, was designed by Domingo de Escondrillas, a Spanish architect who also designed the churches of San Fernando and Pardo in Cebu. Built of coral stone, it is a structure precisely planned in a cruciform layout with three naves in the interior. On the ceiling is a neo-classical retablo painted with biblical scenes. The choir loft at the narthex has a historically valuable pipe organ; however, most of the metal pipes are missing and therefore it is not played.

Plants are growing over the façade and the belfry, threatening the integrity of the structure. The walls are humid and in a dangerous condition, and the tiles on the wooden floor have been replaced by steel sheets. A large room at the back of the main altar on the second floor has been converted into a sacristy museum.

State of Damage

The church has totally collapsed as a result of the earthquake.

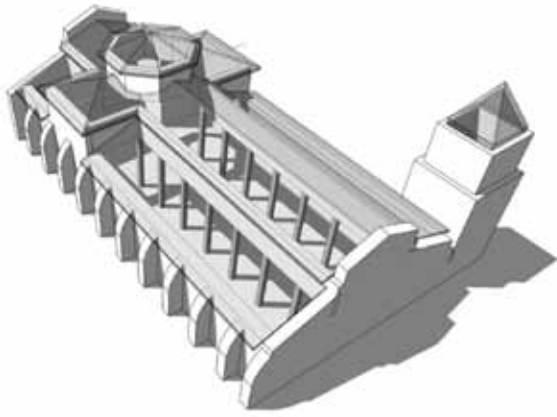

Fig.112 Perspective drawing of Church of Isidore the Farmer



Fig.113 External view of Church of Isidore the Farmer



Fig.114 Church of Isidore the Farmer after earthquake

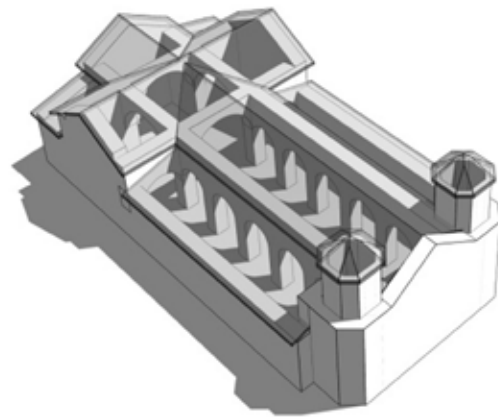

Fig.115 Perspective drawing of Church of Nuestra Señora de la Luz



Fig.116 External view of Church of Nuestra Señora de la Luz



Fig.117 Church of Nuestra Señora de la Luz after earthquake

| Santa Cruz Church

The construction by the Jesuits started in 1798 and finished in 1806. The Recollets replaced the present structure in 1886.

Built of coral stone, it is a cruciform plan with an octagonal cupola. Its façade is planar decorated by thin pilasters and niches with images of saints. In the interior there are three neo-Gothic altars. The church ceiling is made of metal and painted with catechetical and liturgical motifs. The convent is located behind the church and is accessible through the sacristy.

State of Damage

The church has collapsed completely as a result of the earthquake.

| Santo Niño Church

The Santo Niño church is located on top of a hill. Built by the Order of Augustine Recollets in 1880, the bell tower was completed in the 20th century. It was built with coral stone in a cruciform plan with an octagonal cupola. The painted ceiling of the portico in front of an older façade was done by Ray Francia. The main retable is in the Baroque style with Solomonian columns.

State of Damage

The church has collapsed as a result of the earthquake. Though the convent was partially damaged, it is also being used as a school.

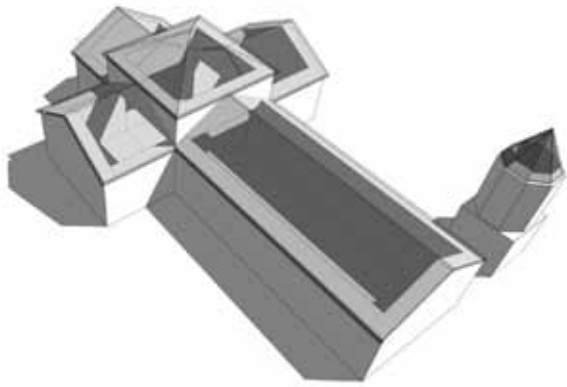

Fig.118 Perspective drawing of Santa Cruz Church



Fig.119 External view of Santa Cruz Church



Fig.120 Santa Cruz Church after earthquake



Fig.121 External view of Santo Niño Church



Fig.122 Inner view of Santo Niño Church after earthquake



Fig.123 Collapse of Santo Niño Church after earthquake

Church of San Pedro

Originally built in 1602, the church was rebuilt in 1638 after a fire. Later in 1734, a newer and bigger church was constructed. After the Baclayon church, it is the second oldest church in Bohol. The Recollets succeeded the Jesuits in their ministry in Loboc in 1768. Father Aquilino Bon built a hexagonal bell tower located 100 meters away from the church. He added a portico and covered the Baroque façade of the Jesuit church and also installed a pipe organ in the 1820s. The church has two façades; the Baroque façade decorated with unfinished medallions depicting saints and the Neo-classical portico added by the Recollets.

The bell tower of Loboc is about 100 meters away from the church. Attached to the building is a three story convent, where there is a small museum of old statues of saints and antique religious artifacts. This building needs much conservation work.

State of Damage

The church, belfry and convent have collapsed as a result of the earthquake.

Baclayon Ancestral Homes Association (Bahandi)

Owners of the Spanish era houses in Baclayon have joined together to preserve the cultural heritage of their local ancestral houses. The association has succeeded in avoiding a road-widening project and demolition of many old houses. Several of the houses are open for guests to stay overnight as a part of a home-stay program.

State of Damage

No serious damage was seen after the earthquake to houses.

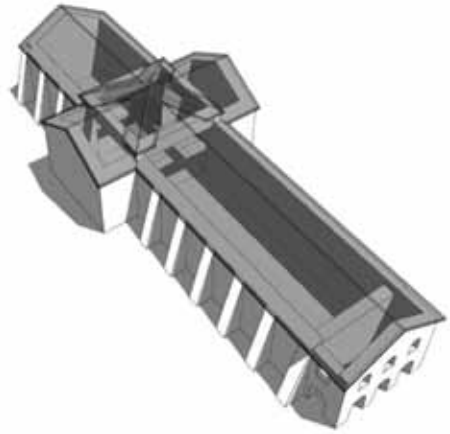

Fig.124 Perspective drawing of Church of San Pedro



Fig.125 External view of Church of San Pedro



Fig.126 External view of Church of San Pedro after earthquake



Fig.127 Interview at Baclayon Ancestral Homes Association and commemorative photo



Fig.128 Residential house



Fig.129 Residential house

5. Observations

5-1. Present State and Issues

Based on the present state of cultural heritage protection in the Philippines that has come to light in this current study, the section below discusses issues that have surfaced as a result of there.

The situation regarding cultural heritage is such that on the whole neither the present state nor value of tangible cultural heritage in the Philippines is well known, and there are few experts who engage in research on cultural heritage protection even within the country. In Spain as well, there are said to be few researchers who engage in research on the cultural heritage of the Philippines as a former Spanish colony. There is actually many cultural heritage, such as folk houses, that are hardly recognized as cultural heritage today but harbor the possibility of being identified as cultural heritage with greater public awareness. However, for the cultural heritage to be recognized as such, it is necessary to strengthen people's awareness of their country's cultural heritage as a whole through exposure to people in other regions in and outside the country.

Additionally, another characteristic of cultural heritage in the Philippines is that there is a relatively large number of cultural heritage sites listed on the World Heritage Tentative List compared to neighboring countries, and from the long-term perspective, it is difficult to identify the cultural heritage which the country deems should have priority protection. As the Philippines is a multiethnic nation, measures for cultural heritage protection must take into consideration the unique history of each ethnic group, regardless of whether heritage is movable or immovable, tangible or intangible. It was also found through local interviews that the targets and departments in charge of cultural heritage protection activities are scattered, so that experience and technologies for cultural heritage protection and restoration have not been accumulated. The execution of the protection framework is in some cases dependent on the political situation in the relevant region, and cooperation with the local administration seems to be the key to proper protection of cultural heritage.

Moreover, according to a Japanese researcher who has conducted local surveys over many years, the nation's level of awareness of the present state of cultural heritage varies according to the security situation in each region. For example, information on the state of cultural heritage protection in Northern Luzon used to be limited in the past, and such information in Mindanao is presently lacking. In other words, the number of cultural heritage that need protection can be expected to increase hereafter, as access to previously inaccessible areas expand with the recent improvement of public security. Depending on the future state of public security improvement, this trend will likely to continue. Another point worthy of note is that disaster prevention measures are lacking on the whole.

The detailed status of cultural heritage protection has been provided in the foregoing chapter in reference to each category, so below let us summarize a new the present state of protection according to issue area.

- Archaeological sites: Excavations are conducted under the initiative of the government (mainly the National Museum). A team of archaeological experts from the National Museum always takes part in excavations conducted in the regions, as well as excavations that are conducted by foreign teams, regardless of whether they are academic excavations or emergency excavations accompanying development projects and such. Next, artifacts are in principle initially kept by regional branches of the National Museum under a policy of onsite safekeeping and display, but they are not given adequate storage or display space. The databases are not computerized, but in paper form, and there are also problems regarding their display and storage methods and safety. At archaeological sites, explanatory boards that provide information on the site are lacking, and the ruins

are frequently displayed without conscious consideration for visitors' safety or protection of the site. However, as there are also local governments that utilize and display archaeological ruins as a sightseeing attraction, any future development and utilization of archaeological sites requires local government cooperation. Among other specific issues is the lack of favorable specimen samples, such as of fish bones and plant seeds, for species-level identification, and the fact that National University, Philippines, presently located in Manila, is the only graduate school that offers a program in archaeology.

- Cooperation requests and proposals for archaeological sites: It is well known among experts that Japan provides assistance particularly to countries in Southeast Asia. Thus, Filipino experts expressed a desire to participate in assistance projects and human resource training projects that Japan is implementing in Southeast Asia. By participating not only in cooperation projects that specifically focus on archaeological sites in the Philippines, but also other projects that Japan is implementing in Southeast Asia, they wish to receive technical cooperation that also promotes information sharing and collaboration between various countries in the future. With regard to excavation surveys, they indicated their wish to broaden the base of archaeology hereafter by strengthening collaboration with educational institutions other than the limited number of universities where archaeology can be studied. For the presentation of archaeological sites, it is necessary to create and erect signboards showing the results of excavation surveys, and to cut grass regularly. Furthermore, in response to the specific issue regarding the lack of specimen samples, a proposal could perhaps be made to provide assistance in producing samples of extant fish and useful plants to identify fish bones and plant seeds unearthed from shell middens.
- Present state of historical buildings: No detailed documentation of churches and other historical buildings has been found. There were examples of the reutilization of buildings other than churches (folk houses, etc.), but most appear to be in danger of being destroyed. Many of the cultural properties that exist today have also undergone considerable changes in external appearance, and the previously tiled roofs of most churches have been changed to corrugated steel roofs. A large number of wooden buildings, mainly including folk houses, still exist today, but no progress has been made at present in the study of their materials. For this reason, it is necessary to promptly clarify the detailed history of historical buildings and their current issues. However, the only universities in the Philippines that teach architectural conservation are the University of Santo Tomas in Manila and the University of San Carlos in Cebu, and the number of cultural properties in the Philippines and the number of institutions for human resource development do not match up. There is already a clear lack of places where people who are placed in charge of the protection of historical buildings, such as regional government office personnel, home owners, architects and restoration staff, can acquire professional knowledge. Lastly, although the country is subject to frequent natural disasters, there are few buildings that incorporate disaster prevention measures.
- Cooperation requests and proposals for historical buildings: Measures need to be taken to cooperate with universities where students can study the conservation of historical buildings and support educational programs for cultural heritage protection. For example, in addition to providing opportunities for studying documentation and building restoration methods, Japanese experts on cultural heritage protection could be sent to the Philippines as instructors. It is also desirable to deepen exchanges with academic institutions, such as by promoting joint surveys by Japanese and Philippine universities. In particular, the accumulation of Japanese studies is expected to benefit joint studies on wooden building materials (ebony, etc.), as well as studies on the strength and structure of tiles.

Conservation and restoration for cultural heritage protection is at times undertaken by staff who are not experts, precisely because there are few expert training institutions to begin with.

In regard to museums, the National Museum offers no pamphlets and catalogues of displays, and is lacking in information materials. A large number of private museums exist, but the completeness of their exhibits and display methods differ greatly from the National Museum. Those that are closely related to a university or other research institution tend to have good exhibits.

Human resource development is an issue, because there are few expert training institutions (one school of archaeology, two schools of architecture). However, as there are many universities, future consideration should be given to increasing the number of universities that provide professional knowledge related to cultural heritage protection. Underwater archaeology is an important field of study in the Philippines, and a number of people have gone to study in Australia and Britain. There is a trend to receive doctoral education and other such advanced education in foreign countries, and a particularly large number of students go to English-speaking countries to study. It is also worthy of mention that there are many doctoral program students from the Philippines who are studying in various research fields in Japan under a support program of the Ministry of Education, Culture, Sports, Science and Technology.

The situation regarding international support for cultural heritage is such that Spain is playing a central role in providing support for Spanish colonial-period properties (church restoration, equipment provision and technical transfer to the public archives, formulation of the Vigan Master Plan, etc.), but no presently ongoing projects were evident, perhaps due in part to the country's recent financial condition. Support for archaeological sites is provided by France (underwater archaeology, Palawan), the United States (Negros, Basilica Minore de San Sebastian in Manila), and Japan (Northern Luzon, Manila, Cebu). Through interviews, it was found that support is also provided by the Netherlands (emergency assistance to churches by the NGO PSF), Germany (National Library), and the Mormons (conversion of historical materials to microfiche). Compared to other countries in Southeast Asia, there are generally fewer support projects, both in terms of those that have been implemented and those that are presently being implemented. This is probably related to the fact that Spain did not necessarily conduct cultural property surveys in the first half of the 19th century as a policy, unlike the situation in Myanmar, which was a British colony, and Cambodia and Vietnam, which were French colonies.

Tourism and regional development is being pursued at the initiative of the government on government-owned land, so implementation is dependent on the political situation in each region. In contrast, properties on private land have little prospect for protection or for use as tourist resources. Development is at a standstill, and guide boards, explanatory panels, safety measures and paths (routes) are lacking in most cases.

5-2. Possibilities for Future Cooperation and Japan's Role

Based on the present state of cultural heritage in the Philippines as discussed above, the study team wishes to propose Japan's contribution to promoting academic cooperation and the human resource development field from the long-term perspective of Philippine-Japan exchanges in consideration of requests from the Philippine side, the situation surrounding cultural heritage in the Philippines, and Japan's fields of specialty. When studying the history of the Philippines, clarifying the history of exchanges with Japan, China, Mexico and Spain beyond the Southeast Asian region is essential to the basic research necessary for cultural heritage protection in the Philippines. There are not many Japanese assistance projects in the Philippines today, but Japan could make a contribution by providing feedback on research achievements that it has accumulated on cultural heritage protection in Asian

countries. Additionally, when providing assistance for the development of experts to supplement their shortage, doing so in conjunction with human resource development projects being implemented in other Asian countries could complement the perspective of the history of exchanges that is indispensable to examining cultural heritage protection in the Philippines as discussed above, as well as enhancement of regional cooperation. Japan also has a role to fulfill in providing assistance for the creation of a framework of multilateral exchanges, by taking Philippine-Japan interactive exchanges a step further and placing them in the context of exchanges with other Asian countries. Just as Japan has experienced an unprecedented disaster and is looking for ways to achieve regional reconstruction centered on culture and cultural heritage, the Philippines is also exploring the need for restoration and reconstruction of its cultural heritage along with the rebuilding of daily lives in the aftermath of a disaster that has inflicted severe damage on churches, the cornerstones of people's lives. Philippine-Japan cooperation is thus desired, in giving long-term thought to disaster prevention measures and cultural heritage protection.

In line with the above proposal, plans for specific assistance from Japan could be considered as follows, based on areas in which Japan excels. An overview is also presented of assistance project examples that have led to implementation promptly after completion of a survey.

① Sharing of specialized knowledge about Hizen (Imari) porcelain, which has been difficult to identify, to contribute to Japan's history of porcelain exchanges

An exchange program was held with a Filipino archaeology researcher under the cultural cooperation program on "Supporting program of the technological improvement for the identification of dates and kiln sites of ceramic sherds as archaeological artifacts —mainly of the Imari wares (Hizen porcelain)" (applicant: Kazuhiko Tanaka) funded by the Japan Foundation. An expert from the Philippines was invited to Japan over a period of 21 days, from October 5 to 25, 2013, and a Japanese expert was sent to the Philippines over a period of 5 days, from February 16 to 20, 2014. The program invited a staff member in charge of ceramic items at the National Museum

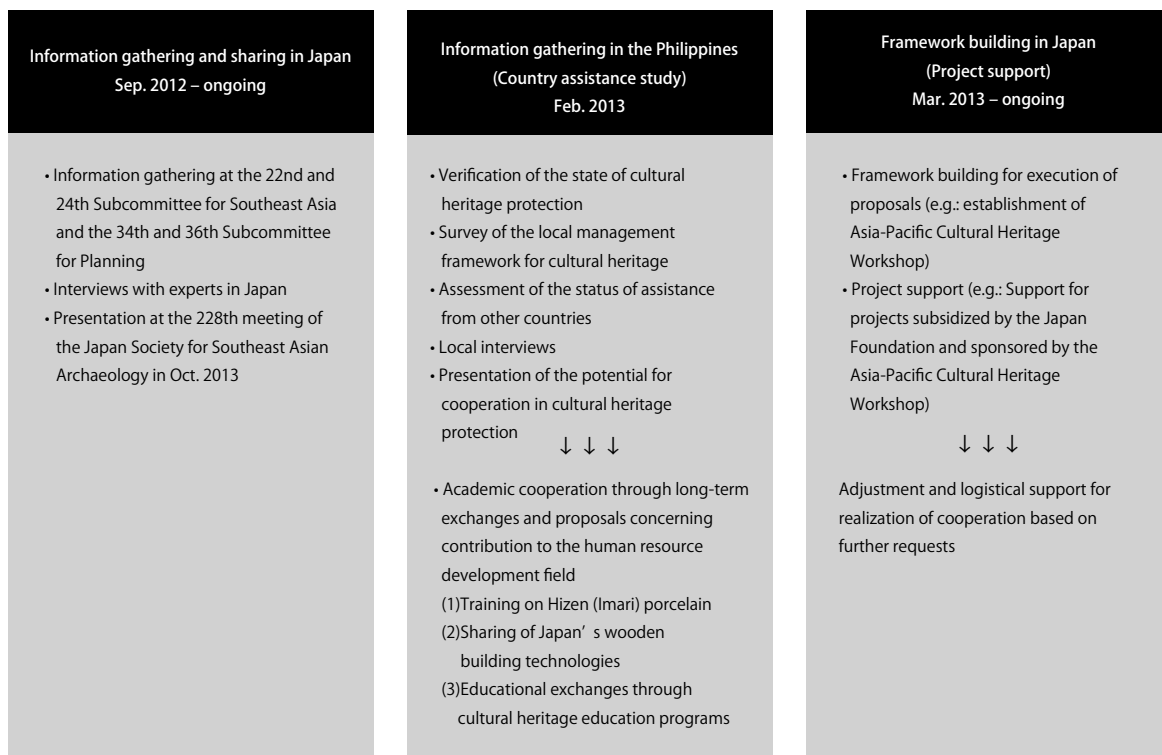

Fig.130 Support of Philippine programs by the Consortium

of the Philippines to Arita, one of the largest ceramic production regions in Japan with a wealth of ceramic studies, to provide concentrated technical support for acquisition and enhancement of basic knowledge of ceramic artifacts, examination methods, classification technologies for identification of production regions and dates, and documentation technologies, and to help develop experts in the organization and utilization of ceramic materials. As a related event, a workshop was scheduled to be held in the Philippines for a presentation of the results of the program. From the Philippines, Ms. Nida Cuevas participated in the invitation program. In addition to onsite training in the town of Arita, Saga Prefecture (History and Folklore Museum of Arita), training was also provided in the town of Hasamicho in Nagasaki Prefecture (Hasamicho Board of Education) and Nagasaki City (Nagasaki City Board of Education). Ms. Cuevas toured the town of Arita (Kyushu Ceramic Museum) and Nagasaki City (Nagasaki Museum of History and Culture), and acquired deeper basic knowledge. In Tokyo and its environs, she toured Tokyo (Tokyo National Museum) and Yokohama (Yokohama Museum of Eurasian Cultures), as well as participating in a workshop of the Japan Society for Southeast Asian Archaeology, and deepened exchanges with researchers of Southeast Asian archaeology in Japan. To present the results of the above training program, Tanaka (applicant) and Ms. Cuevas held a workshop at the National Museum of the Philippines in February 2014.

Recent excavation surveys conducted in metro Manila have yielded an increasing amount of ceramic artifacts, but before the training program, they had been left untouched without being sorted, and were not made full use of. The program, however, has developed researchers with specialized knowledge of ceramics in the Philippines, making it possible to classify the basic production regions of ceramic artifacts, such as whether they were produced in Japan or China, which was previously difficult to do. Additionally, the significance of developing Filipino experts who can identify Japanese Hizen porcelain through such programs as the recent training program was not previously fully recognized in the Philippines, but holding a workshop to communicate the significance of the program to Filipino researchers who have particular interest in ceramics raised awareness of studies of Japanese porcelain in the Philippines, as well as studies of Asian ceramics.

② Support for basic educational programs for cultural heritage protection (documentation, restoration of buildings, disaster prevention planning), promotion of Philippine-Japan exchanges in the academic field, and joint promotion of research utilizing Japan's accumulation of studies on wooden building tiles, earthquake resistance, materials (such as ebony etc.), and other.

Consideration is being given to holding a workshop under the leadership of Melva Java, Associate Professor, College of Architecture and Fine Arts, University of San Carlos in Cebu, and Juan Ramon Jimenez Verdejo, Associate Professor, the University of Shiga Prefecture, toward the restoration and recovery of churches that suffered damage in the earthquake that hit Cebu and Bohol Islands in 2013. Intended for various local stakeholders and both local and foreign experts who are considering providing assistance, the workshop will not only examine measures for restoration and recovery of the churches using Japan's experience of reconstruction from natural disaster, but will also cover such themes as the improvement of cultural heritage awareness, enhancement of educational programs, and cooperation between public and academic institutions. At the same time, consideration is also being given to the installation of temporary falseworks for prevention of further collapsing. Toward realizing these measures, applications are being made for subsidies from Japan and a number of other countries.

The above plans have already been launched in specific terms, but in order to commence other specific assistance programs, it is necessary to inform the many parties concerned in Japan about the present state of cultural heritage in the Philippines. Based on this awareness, a report has been presented at a subcommittee in the Consortium, and an oral presentation has been made of the details of the recent survey at the 228th regular meeting of the Japan

Society for Southeast Asian Archaeology held in October 2013.

5-3. Role of the Japan Consortium for International Cooperation in Cultural Heritage

The Consortium aims to contribute to international efforts for cultural heritage protection by coordinating and promoting cooperation among relevant players in Japan. With regard to the Philippines, as well, coordination and cooperation will be promoted in Japan for continued implementation of the above-described proposals, and measures will be taken to share information and introduce experts as required. At the same time, information on experts who are familiar with cultural heritage in the Philippines will be collected and shared among Consortium members and other experts as necessary, and information referrals will be made to relevant institutions. As part of this effort, this particular study report will be sent to all Consortium members, and an electronic version will be made available on the Consortium's website. Also through reports to the Consortium's subcommittees, information about this study will continue to be provided to relevant institutions such as the Agency for Cultural Affairs, the Ministry of Foreign Affairs, the Japan Foundation, and the Japan International Cooperation Agency. Furthermore, cooperation with the Philippine National Commission for Culture and the Arts, including liaison councils, can also be expected to continue, so that further invitations and exchanges may be planned between the Commission and Japanese experts.

It is worth noting that information that has been collected through this study on experts on cultural heritage in the Philippines in Japan has allowed the details of the state of damage that was inflicted on cultural properties in the Philippines to be known immediately on the very day of the earthquake that struck Cebu and Bohol Islands in October 2013 following the recent local survey, via the Internet and locally established networks. Thereafter, an expert who traveled to the islands to personally survey the damage gave a report at the Consortium's Subcommittee for Southeast Asia, and the Consortium was able to gain a damage status report within two months of the earthquake and share information on the state of damage to cultural properties via mail news. The prompt information gathering and sharing was possible precisely because the Consortium had assessed the state of cultural properties in the Philippines in advance, and is an example of how the Consortium's network has been fully utilized to fulfill its mission.

5-4. Summary

The study team visited the Philippines to assess the present state of cultural heritage protection in the country, seek a direction for future international cooperation, and examine specific requests for assistance from the Philippine side. The local survey consisted of visits to representative cultural properties such as colonial-period towns and churches, prehistoric archaeological sites, as well as museums and libraries throughout the country, and information was acquired and views were exchanged through interviews with relevant authorities at each site.

The study revealed that cultural properties in the Philippines are facing a conservation crisis, and that there is a definite shortage of human resources and facilities. Most of all, disaster countermeasures were saliently lacking, even though the country is situated in a region subject to frequent natural disasters. The earthquake and typhoon that hit the Philippines after the recent survey brought severe damage to the country's invaluable cultural heritage, particularly as a result of the earthquake, but there are yet no prospects for restoration and reconstruction. Future assistance is thus needed particularly for technical transfers and human resource development in the field of conservation and restoration technologies, as well as for the rebuilding of cultural properties as cornerstones of local communities and for the formulation of a comprehensive plan from the perspective of regional development.

The study was able to be carried out efficiently through cooperation with the Philippine National Commission

for Culture and the Arts. The study team wishes to extend its appreciation to the Commission for its cooperation in providing for the team's various needs, such as the accompaniment of a local authority when visiting the sites and the arrangement of interviews.

Today's Philippine-Japan relationship is in the process of development centered on culture based on the "Cultural WA Project," a new Asia cultural exchange policy that was announced on the occasion of the 40th year of Japan-ASEAN friendship and cooperation in 2013. The study team hopes to maintain the relationship of trust it has cultivated with its counterparts in the Philippines through this recent study and to examine optimal assistance measures in consultation with relevant institutions. Ultimately, the study team hopes that Japan contributes to further strengthening the bonds of mutual friendship and understanding between the Philippines and Japan through international cooperation for cultural heritage protection, which is expected to gain momentum in the near future.

APPENDIX

APPENDIX 1. Laws Concerning Cultural Heritage Protection

We obtained the English version of "AN ACT PROVIDING FOR THE PROTECTION AND CONSERVATION OF THE NATIONAL CULTURAL HERITAGE, STRENGTHENING THE NATIONAL COMMISSION FOR CULTURE AND THE ARTS (NCCA) AND ITS AFFILIATED CULTURAL AGENCIES, AND FOR OTHER PURPOSES"; "AN ACT PROVIDING FOR THE PROTECTION AND CONSERVATION OF THE NATIONAL CULTURAL HERITAGE, STRENGTHENING THE NATIONAL COMMISSION FOR CULTURE AND THE ARTS (NCCA) AND ITS AFFILIATED CULTURAL AGENCIES, AND FOR OTHER PURPOSES"; "AN ACT STRENGTHENING PEOPLES' NATIONALISM THROUGH PHILIPPINE HISTORY BY CHANGING THE NOMENCLATURE OF THE NATIONAL HISTORICAL INSTITUTE INTO THE NATIONAL HISTORICAL COMMISSION OF THE PHILIPPINES STRENGTHENING ITS POWERS AND FUNCTIONS, AND FOR OTHER PURPOSES" from The National Commission for Culture and the Arts of the Philippines. The original text in Filipino and the Japanese translation were referenced in "Series of instruments for protecting cultural property [17] Philippines" published by the Japan Center for International Cooperation in Conservation, National Research Institute for Cultural Properties, Tokyo.

S. No.3014

H. No. 6733

Republic of the Philippines
Congress of the Philippines
Metro Manila
Fourteenth Congress
Third Regular Session

Begun and held in Metro Manila, on Monday, the twenty-seventh day of July, two thousand nine.

[REPUBLIC ACT No. 10066]

AN ACT PROVIDING FOR THE PROTECTION AND CONSERVATION OF THE NATIONAL CULTURAL HERITAGE, STRENGTHENING THE NATIONAL COMMISSION FOR CULTURE AND THE ARTS (NCCA) AND ITS AFFILIATED CULTURAL AGENCIES, AND FOR OTHER PURPOSES

Be it enacted by the Senate and House of Representatives of the Philippines in Congress assembled:

SECTION 1. Short Title. – This Act shall be known as the “National Cultural Heritage Act of 2009”.

ARTICLE I POLICES AND PRINCIPLES

SEC. 2. Declaration of Principles and Policies. – Sections 14, 15, 16 and 17, Article XIV of the 1987 Constitution declare that the State shall foster the preservation, enrichment and dynamic evolution of a Filipino culture based on the principle of unity in diversity in a climate of free artistic and intellectual expression. The Constitution likewise mandates the State to conserve, develop, promote and popularize the nation’s historical and cultural heritage and resources, as well as artistic creations. It further provides that all the country’s artistic and historic wealth constitutes the cultural treasure of the nation and shall be under the protection of the State, which may regulate its disposition.

In the pursuit of cultural preservation as a strategy for maintaining Filipino identity, this Act shall pursue the following objectives:

- (a) Protect, preserve, conserve and promote the nation's cultural heritage, its property and histories, and the ethnicity of local communities;
- (b) Establish and strengthen cultural institutions; and
- (c) Protect cultural workers and ensure their professional development and well-being.

The State shall likewise endeavor to create a balanced atmosphere where the historic past coexists in harmony with modern society. It shall approach the problem of conservation in an integrated and holistic manner, cutting across all relevant disciplines and technologies. The State shall further administer the heritage resources in a spirit of stewardship for the inspiration and benefit of the present and future generations.

ARTICLE II DEFINITION OF TERMS

SEC. 3. Definition of Terms. – For purposes of this Act, the following terms shall be defined as follows:

- (a) "Adaptive reuse" shall refer to the utilization of buildings, other built-structures and sites of value for purposes other than that for which they were intended originally, in order to conserve the site, their engineering integrity and authenticity of design.
- (b) "Anthropological area" shall refer to any place where studies of specific ethno-linguistic groups are undertaken, the properties of which are of value to our cultural heritage.
- (c) "Antique" shall refer to a cultural property found locally which is one hundred (100) years in age, more or less, the production of which has ceased.
- (d) "Archaeological area" shall refer to any place, whether above or under ground, underwater or at sea level, containing fossils, artifacts and other cultural, geological, botanical, zoological materials which depict and document culturally relevant paleontological, prehistoric and/or historic events.
- (e) "Archives" shall refer to public and private records in any format which have been selected for permanent preservation because of their evidential, historical informational value; otherwise known as archival materials collections or archival holdings; the place (building/room/storage area) where archival materials are kept and preserved; and an organization or agency or part thereof whose main responsibility is to appraise, arrange, describe, conserve, promote and make archival materials available for reference and research, also known as archival agency.
- (f) "Built heritage" shall refer to architectural and engineering structures such as, but not limited to, bridges, government buildings, house of ancestry, traditional dwellings, quartels, train stations, lighthouses, small ports, educational, technological and industrial complexes, and their settings, and landscapes with notable historical and cultural significance.
- (g) "Collector" shall refer to any person who or institution that acquires cultural property for purposes other than sale.
- (h) "Commission" shall refer to the National Commission for Culture and the Arts (NCCA).
- (i) "Conservation" shall refer to all the processes and measures of maintaining the cultural significance of a cultural property including, but not limited to, preservation, restoration, reconstruction, protection, adaption or any combination thereof.
- (j) "Cultural agencies" shall refer to the following national government agencies with their specific areas of responsibility: National Museum (cultural property); the National Library (books); National Historical Institute (Philippine history); National Archives (documents); Cultural Center of the Philippines (culture and the arts); and Komisyon sa Wikang Filipino (language).
- (k) "Cultural education" shall refer to the teaching and learning of cultural concepts and processes.
- (l) "Cultural heritage" shall refer to the totality of cultural property preserved and developed through time and passed on to posterity.
- (m) "Cultural heritage worker" shall refer to an individual undertaking cultural heritage work.
- (n) "Cultural institution" shall refer to entities engaged primarily in cultural work.
- (o) "Cultural property" shall refer to all products of human creativity by which a people and a nation reveal their identity, including churches, mosques and other places of religious worship, schools and natural history specimens and sites, whether public or privately-owned, movable or immovable, and tangible or intangible.
- (p) "Dealers" shall refer to natural or juridical persons who acquire cultural property for the purpose of engaging in the acquisition and disposition of the same.

- (q) "Heritage zone" shall refer to historical, anthropological, archaeological, artistic geographical areas and settings that are culturally significant to the country, as declared by the National Museum and/or the National Historical Institute.
- (r) "History" shall refer to a written record of past events relating to Philippine history.
- (s) "Historical landmarks" shall refer to sites or structures that are associated with events or achievements significant to Philippine history as declared by the National Historical Institute.
- (t) "Historical monuments" shall refer to structures that honor illustrious persons or commemorate events of historical value as declared by the National Historical Institute.
- (u) "Historical shrines" shall refer to historical sites or structures hallowed and revered for their history or association as declared by the National Historical Institute.
- (v) "Historical street name" shall refer to a street name which has been in existence for at least fifty (50) years and over time has been considered historic.
- (w) "Important cultural property" shall refer to a cultural property having exceptional cultural, artistic and historical significance to the Philippines, as shall be determined by the National Museum and/or National Historical Institute.
- (x) "Intangible cultural heritage" shall refer to the practices, representations, expressions, knowledge and skills, as well as the instruments, objects and artifacts associated therewith, that communities, groups and individuals recognize as part of their cultural heritage, such as: (1) oral traditions, languages and expressions; (2) performing arts; (3) social practices, rituals and festive events; (4) knowledge and practices concerning nature and the universe; and (5) traditional craftsmanship.
- (y) "Intangible cultural property" shall refer to the peoples' learned processes along with the knowledge, skills and creativity that inform and are developed by them, the products they create and the resources, spaces and other aspects of social and natural context necessary for their sustainability.
- (z) "Library" shall refer to an institution where the collection of books, manuscripts, computerized information and other materials are organized to provide physical, bibliographic and/or intellectual access to the public, with a librarian that is trained to provide services and programs related to the information needs of its clientele.
- (aa) "Museum" shall refer to a permanent institution that researches, acquires, conserves, communicates and exhibits the material evidence of humans and their environment for purposes of education or leisure.
- (bb) "National cultural treasure" shall refer to a unique cultural property found locally, possessing outstanding historical, cultural, artistic and/or scientific value which is highly significant and important to the country and nation, and officially declared as such by pertinent cultural agency.
- (cc) "Nationally significant" shall refer to historical, aesthetic, scientific, technical, social and/or spiritual values that unify the nation by a deep sense of pride in their various yet common identities, cultural heritage and national patrimony.
- (dd) "Natural property or cultural significance" shall refer to areas possessing outstanding ecosystem with flora and fauna of national scientific importance under the National Integrated Protected Areas System.
- (ee) "NCCA Portal Cultural Databank" refers to the specific domain in the Commission's intranet for cultural information that is accessed only internally with control and confidentiality. It includes the registry of national cultural property.
- (ff) "Prehistory" shall refer to the period of human history before the introduction of the forms of writing.
- (gg) "Registry" shall refer to the Philippines Registry of Cultural Property which is the registry of all cultural property of the country deemed of significant importance to our cultural heritage.
- (hh) "Restoration" shall refer to the action taken or the technical intervention to correct deterioration and alterations.
- (ii) "Tangible cultural property" shall refer to a cultural property with historical, archival, anthropological, archaeological, artistic and architectural value, and with exceptional or traditional production, whether of Philippine origin or not, including antiques and natural history specimens with significant value.

ARTICLE III CULTURAL PROPERTY

SEC. 4. Categories. – The cultural property of the country shall be categorized as follows:

- (a) National cultural treasures;

- (b) Important cultural property;
- (c) World heritage sites;
- (d) National historical shrine;
- (e) National historical monument; and
- (f) National historical landmark.

SEC. 5. Cultural Property Considered Important Cultural Property. – For purposes of protecting a cultural property against exportation, modification or demolition, the following works shall be considered important cultural property, unless declared otherwise by the pertinent cultural agency:

Unless declared by the Commission,

- (a) Works by a Manlilikha ng Bayan;
- (b) Works by a National Artist;

Unless declared by the National Museum,

- (c) Archaeological and traditional ethnographic materials;

Unless declared by the National Historical Institute,

- (d) Works of national heroes;
- (e) Marked structure;
- (f) Structures dating at least fifty (50) years old; and

Unless declared by the National Archives,

- (g) Archival material/document dating at least fifty (50) years old.

The property owner may petition the appropriate cultural agency to remove the presumption of important cultural property which shall not be unreasonably withheld.

SEC. 6. World Heritage Sites. – The appropriate cultural agency shall closely collaborate with the United Nations Educational Scientific and Cultural Organization (UNESCO) National Commission of the Philippines in ensuring the conservation and management of world heritage sites, of cultural and mixed sites category, in the Philippines.

SEC. 7. Privileges of Cultural Property. – All cultural properties declared as national cultural treasures and national historical landmarks, sites or monuments shall be entitled to the following privileges:

- (a) Priority government funding for protection, conservation and restoration;
- (b) Incentive for private support of conservation and restoration through the Commission's Conservation Incentive Program for national cultural treasures;
- (c) An official heritage marker placed by the cultural agency concerned indicating that the immovable cultural property has been identified as national cultural treasures and/or national historical landmarks, sites or monuments; and
- (d) In times of armed conflict, natural disasters and other exceptional events that endanger the cultural heritage of the country, all national cultural treasures or national historical landmarks, sites or monuments shall be given priority by the government.

All cultural properties declared as important cultural property may also receive government funding for its protection, conservation and restoration. An official heritage maker shall likewise be placed on an immovable cultural property to identify the same as important cultural property.

SEC. 8. Procedure for Declaration, or Delisting of National Cultural Treasures or Important Cultural Property. – The procedure in declaring as well as in delisting a national cultural property or an important cultural property

shall be as follows:

- (a) A declaration or a delisting of a cultural property as a national cultural treasure or an important cultural property shall commence upon the filing of a petition by the owner, stakeholder or any interested person, with the Commission, which shall refer the matter to the appropriate cultural agency;
- (b) Upon verification of the suitability of the property as a national cultural treasure or an important cultural property, the cultural agency concerned shall send notice of hearing to the owner and stakeholders. Stakeholders including, but not limited to, local government units, local culture and arts council, local tourism councils, nongovernment conservation organizations, and schools, may be allowed to file their support or opposition to the petition;
- (c) The owner and/or other stakeholders shall file their position paper within fifteen (15) days from receipt of the notice of hearing, furnishing all the parties, including the appropriate cultural agency, with such position paper. Extensions may be allowed, but in no case shall it exceed more than thirty (30) days;
- (d) The petitioner/stakeholder shall give their answer within fifteen (15) days upon receipt of any position paper. Thereafter, no further submissions shall be allowed; and
- (e) The appropriate cultural agency shall have a maximum of ninety (90) days from the deadline of the submission of all the answers within which to submit its resolution and render its decision on the application.

SEC. 9. Right of First Refusal on the Sale of National Cultural Treasures. – The appropriate cultural agency shall be given the right of first refusal in the purchase of cultural properties declared as national cultural property. Prior to the finality of the sale, the appropriate cultural agency may likewise match any offer made for the purchase of national cultural property.

SEC. 10. Licensing of Dealers of Cultural Property. – All dealers of cultural property shall secure a license to operate as such from the appropriate cultural agency concerned. They shall submit a quarterly inventory of items carried which shall include a history of each item. Failure to submit two (2) consecutive inventories shall be a ground for cancellation of the license. All dealers of cultural property shall be subject to inspection by the concerned cultural agencies.

The cultural agencies may charge and collect fees for registration as well as for licenses, inspections, certifications, authorizations and permits that they issue and undertake in connection with the implementation of this Act. Funds generated from these collections by cultural agencies shall be retained by the cultural agency concerned for its operations.

SEC. 11. Dealing of Cultural Property. – No cultural property shall be sold, resold or taken out of the country without first securing a clearance from the cultural agency concerned. In case the property shall be taken out of the country, it shall solely be for the purpose of scientific scrutiny or exhibit.

ARTICLE IV HERITAGE ZONES

SEC. 12. Designation of Heritage Zones. – The National Historical Institute and the National Museum, in consultation with the Commission and the Housing and Land Use Regulatory Board or other concerned agencies, shall designate heritage zones to protect the historical and cultural integrity of a geographical area.

SEC. 13. Maintenance of Heritage Zones. – A heritage zone shall be maintained by the local government unit concerned, in accordance with the following guidelines:

- (a) Implementation of adaptive reuse of cultural property;
- (b) Appearance of streets, parks, monuments, buildings, and natural bodies of water, canals, paths and barangays within an locality shall be maintained as close to their appearance at the time the area was of most importance to Philippine history as determined by the National Historical Institute; and

(c) Local government units shall document and sustain all sociocultural practices such as, but not limited to, traditional celebrations, historical battles,, recreation of customs, and the reenactment of battles and other local customs that are unique to a locality.

ARTICLE V REGISTRATION AND CONSERVATION OF CULTURAL PROPERTY

SEC. 14. *Establishment of a Philippine Registry of Cultural Property.* – All cultural properties of the country deemed important to cultural heritage shall be registered in the Philippine Registry of Cultural Property.

The Commission, through the appropriate cultural agencies and local government units, shall establish and maintain this Registry within three (3) year from the effectivity of this Act. The guidelines in the registration of cultural property are as follows:

- (a) All cultural agencies concerned shall individually maintain an inventory, evaluation and documentation of all cultural properties declared according to their category and shall submit the same to the Commission. For cultural property declared as immovable cultural property, the appropriate cultural agency shall, after registration, give due notice to the concerned Registry of Deeds for annotation on the land titles pertaining to the same;
- (b) Local government units, through their cultural offices, shall likewise maintain an inventory of cultural property under its jurisdiction and shall furnish the Commission a copy of the same;
- (c) Both cultural agencies concerned and local government units shall continuously coordinate in making entries and in monitoring the various cultural properties in their respective inventory;
- (d) All government agencies and instrumentalities, government-owned and/or -controlled corporations and their subsidiaries, including public and private educational institutions, shall report their ownership and/or possession of such items to the pertinent cultural agency and shall register such properties within three (3) years from the effectivity of this Act;
- (e) Private collectors and owners of cultural property shall register such properties within three (3) years from the effectivity of this Act. The private collectors and owners of cultural property shall not be divested of their possession and ownership thereof even after registration of said property as herein required.

Information on registered cultural properties owned by private individuals shall remain confidential and may be given only upon prior consent of the private owner. The Commission shall operate the Registry in the NCCA portal cultural databank.

SEC. 15. *Conservation of Cultural Property.* – All intervention works and measures on conservation of national cultural treasures, important cultural property, as well as national historical landmarks, sites or monuments and structures previously marked by the National Museum and/or the National Historical Institute before the implementation of this Act, shall be undertaken through the appropriate cultural agency which shall supervise the same.

The appropriate cultural agency shall approve only those methods and materials that strictly adhere to the accepted international standards of conservation.

SEC. 16. *Documentation and Preservation of Traditional and Contemporary Arts.* – Local government units shall document traditional and contemporary arts and crafts, including their processes and makers, and sustain the sources of their raw materials. Local government units shall encourage and sustain traditional arts and crafts as active and viable sources of income for the community.

The Commission, the Department of Trade and Industry, the Department of Tourism and other government agencies involved directly or indirectly in the production of goods shall assist the local government units in protecting their traditional and contemporary arts and crafts, making them viable for current and future markets, with a view to encouraging and promoting the unique heritage and identities of said communities.

The local government unit concerned shall submit an annual inventory of these documentations to the Commission, which will be included in the Philippine Registry of Cultural Property, as established in Section 14 of this Act.

SEC. 17. Systematic Research in Natural History. – The National Museum shall have the authority to collect, maintain and develop the national reference collections of Philippine flora and fauna, rocks and minerals through research and field collections specimens including important cultural property within the territorial jurisdiction of the Philippines. It shall be exempt from any and all permit systems regulating the same.

The National Museum shall inform the Department of Environment and Natural Resources and the Department of Agriculture of such collection. All types of specimen collected in the Philippine territory shall be deposited in the National Museum.

SEC. 18. Heritage Agreements. – The Commission, upon advice of the concerned cultural agency, may enter into agreements with private owners of cultural properties with regard to the preservation of said properties.

Such agreement shall be in the form of a contract and may include such terms and conditions including, but not limited to:

- (a) Public access to the property;
- (b) Value of the encumbrance;
- (c) Duration of the servitude of the property;
- (d) Restriction of the right of the owner or occupant to perform acts on or near the place;
- (e) Maintenance and management of the property;
- (f) Provision of financial assistance for the conservation of the property; and
- (g) Procedure for the resolution of any dispute arising out of the agreement.

Such agreement should be annotated in the land title to bind future owners and/or occupants of the immovable cultural property.

SEC. 19. National Inventory of Intangible Cultural Heritage. – The appropriate cultural agency shall closely collaborate with the UNESCO National Commission of the Philippines in safeguarding intangible cultural heritage in the Philippines. The Philippine Intangible Cultural Heritage Committee established by the UNESCO National Commission of the Philippines shall continue to take the lead role in implementing the provisions of the UNESCO Convention for the Safeguarding of the Intangible Cultural Heritage, with particular attention to Articles 11 to 15 of the said Convention.

SEC. 20. Immovable National Cultural Treasures. – Immovable national cultural treasures shall not be relocated, rebuilt, defaced or otherwise changed in a manner, which would destroy the property's dignity and authenticity, except to save such property from destruction due to natural causes.

The site referred to in this provision may only be moved after securing a permit from the Commission or the appropriate cultural agency.

SEC. 21. Indigenous Properties. – The appropriate cultural agency, in consultation with the National Commission on Indigenous Peoples, shall establish a program and promulgate regulations to assist indigenous people in preserving their particular cultural and historical properties.

SEC. 22. Renaming of Historical Streets, Buildings Designated as Cultural Treasure or Important Cultural Property. – The names of historical streets, parks, buildings, shrines, landmarks, monuments and sites designated as national cultural treasures or important cultural property shall not be allowed to be renamed by a local or national legislation, unless approved by the National Historical Institute, and only after due hearing on the matter. Furthermore, for changes of names done to historical streets, parks, buildings, shrines, landmarks, monuments, and sites prior to the effectivity of this Act, the National Historical Institute may direct the local government units to restore their original names, also after due hearing.

ARTICLE VI REGULATING THE EXPORT, TRANSIT, IMPORT AND REPATRIATION OF CULTURAL PROPERTY

SEC. 23. Export of Cultural Property. – Whoever desires to export cultural property registered in the Philippine Registry of Cultural Property shall adhere to the following requirements:

- (a) Authorization from the Commission through the appropriate cultural agencies;
- (b) Application for export permit shall be submitted thirty (30) days before the intended export from the Philippines; and
- (c) Application for export permit must include the following: (1) the purpose of the temporary export; (2) the export date of the cultural property; (3) the repatriation date of the cultural property; (4) a description of the cultural property; and (5) the inventory of the cultural property in the Philippine Registry of Cultural Property.

The grant of export permit shall be based on the following conditions: (i) the cultural property is exported on a temporary basis; and (ii) export of cultural property is necessary for scientific scrutiny or exhibit.

SEC. 24. Repatriation Claims and Agreements. – Should the cultural property registered in the Philippine Registry of Cultural Property be illicitly exported from the country, the Department of Foreign Affairs shall, upon the recommendation of the appropriate cultural agency, claim the right of repatriation vis-à-vis all other contracting States. Any compensation and costs shall be carried by the Philippine government.

For the protection of cultural and foreign affairs interests and to secure cultural heritage, the Philippines may conclude international treaties with contracting States on the import and repatriation of cultural property subject to the following conditions:

- (a) The scope of the agreement must be cultural property of significant importance to the cultural heritage of the contracting States;
- (b) The cultural property must be subject to the existing export policies for the purpose of protecting cultural heritage; and
- (c) The contracting States shall grant reciprocal rights.

ARTICLE VII POWERS OF THE COMMISSION/CULTURAL AGENCIES

SEC. 25. Power to Issue a Cease and Desist Order. – When the physical integrity of the national cultural treasures or important cultural properties are found to be in danger of destruction or significant alteration from its original state, the appropriate cultural agency shall immediately issue a Cease and Desist Order ex parte suspending all activities that will affect the cultural property. The local government unit which has the jurisdiction over the site where the immovable cultural property is located shall report the same to the appropriate cultural agency immediately upon discovery and shall promptly adopt measures to secure the integrity of such immovable cultural property. Thereafter, the appropriate cultural agency shall give notice to the owner or occupant of the cultural property and conduct a hearing on the propriety or the issuance of the Cease and Desist Order. The suspension of the activities shall be lifted only upon the written authority of the appropriate cultural agency after the notice and hearing involving the interested parties and stakeholders.

SEC. 26. Power to Issue Compulsory Repair Order. – When a privately-owned heritage site cannot be maintained by the owner or has fallen into disrepair through neglect to such an extent that it will lose its potential for conservation, the appropriate cultural agency may serve on the owner or occupant of such property an order to repair or maintain such site. If the owner fails to comply with the said order within thirty (30) to forty-five (45) days, repairs may be undertaken by the appropriate cultural agency funded by the Commission for the account of the owner.

SEC. 27. Visitorial Powers. – The cultural agencies concerned, through the Commission, are hereby given the power to inspect national cultural treasures, important cultural properties, and national historical landmarks, sites or monuments at any time to ensure the protection and integrity of such. They may also inspect public or private collections or objects that may be categorized as cultural property: Provided, That in the case of private collections or objects, the prior written consent of the owner shall be obtained.

SEC. 28. Power to Deputize Other Government Agencies. – The cultural agencies concerned, as well as the Commission, shall have the power to deputize the Philippine National Police, the National Bureau of Investigation, the Armed Forces of the Philippines, the Philippine Coast Guard, and other local or national law enforcement agencies, including the Bureau of Fisheries' agents, the Department of Environment and Natural Resources' rangers, the Bureau of Customs and the Bureau of Immigration agents, members of the Office of the Special Envoy on Transnational Crimes and other such agencies and their successors-interest, to enforce the provisions of this Act and its implementing rules and regulations. The said agencies shall immediately detail their respective personnel to protect the cultural items under the National Registry.

Failure to follow deputization order of the concerned cultural agency as well as the Commission shall be penalized in accordance with Section 49 herein.

SEC. 29. Power to Recover Cultural Properties. – The Commission is empowered to recover or retrieve cultural properties which are under the custody of foreign nationals or entities and to bring these properties back to Philippine custody.

SEC. 30. Anthropological Research and Archaeological Exploration/Excavation. – (a) The National Museum, with respect to cultural/archaeological/anthropological matters, and the National Historical Institute, with respect to historical anthropological matters, shall regulate and control all anthropological research conducted by foreigners; and all archaeological excavation or exploration. Pursuant to the foregoing, the National Museum or the National Historical Institute shall deputize other agencies to protect archaeological and anthropological sites. It shall be guided by the following rules:

- (1) All cultural properties found in terrestrial and/or underwater archaeological sites belong to the State;
- (2) No terrestrial and/or underwater archaeological explorations and excavations for the purpose of obtaining materials and data of cultural value shall be undertaken without written authority and direct supervision by archaeologists and/or representatives of the National Museum;
- (3) All anthropological researches, for the purpose of obtaining materials and data of cultural value and where the principal proponent is a foreign national, shall be undertaken only with the authority and under the supervision of the National Museum or the National Historical Institute. Anthropological research by Philippine nationals, especially members of the indigenous communities, shall be encouraged;
- (4) Archaeological or anthropological materials presumed as important cultural property shall be allowed to leave the country only upon proper evaluation and written permission of the National Museum or the National Historical Institute;
- (5) All explorations and excavations undertaken, wherein the caves, rock shelters and their vicinities may have been used in the prehistoric past by man either for habitation, religious and/or sacred and burial purposes all over the country, shall be under the direct jurisdiction and supervision of archaeologists and/or other experts of the National Museum;

(6) All mining activities inside caves, rock shelters and any such other areas shall require a written permit and clearance from the National Museum. An appropriate prior inspection by representatives of the National Museum, funded by the company applying for a mining right, shall be required to ensure that no archaeological materials are present and destroyed;

(7) Excavations in caves, rock shelters and other areas by laymen are prohibited by this Act. All earth-moving activities in these areas must have the proper permit and clearance from the National Museum and monitored by their representatives;

(8) All treasure hunting permits and licenses shall be issued by the National Museum, which shall formulate the rules and regulations to adequately control, regulate and monitor all applicants for such undertakings; and

(9) The provisions of this Act on explorations and excavations of terrestrial and underwater archaeological sites shall supersede all local, municipal, regional and autonomous regional governments' resolutions and ordinances.

(b) When the presence of any cultural or historical property is discovered, the National Museum or the National Historical Institute shall immediately suspend all activities that will affect the site and shall immediately notify the local government unit having jurisdiction of the place where the discovery was made. The local government shall promptly adopt measures to protect and safeguard the integrity of the cultural property so discovered and, within five (5) days from the discovery, shall report the same to the appropriate agency. The suspension of these activities shall be lifted only upon the written authority of the National Museum or the National Historical Institute and only after the systematic recovery of the archaeological materials.

(c) The Commission, upon the recommendation of the appropriate cultural agency, shall provide incentives for persons who discover and report heretofore unknown archaeological sites, in accordance with its rules and regulations implementing the provisions of this Act.

(d) Any government or nongovernment infrastructure project or architectural site development shall include anthropological, archaeological and historical and heritage site conservation concerns in their Environmental Impact Assessment System.

ARTICLE VIII ROLE OF CULTURAL AGENCIES

SEC. 31. Responsibilities of Cultural Agencies for Designation of Cultural Property. – The cultural agencies, in conformity with their respective charters and mandates, shall define and delineate their respective areas of responsibility with respect to cultural property and assessment of national cultural treasures and national historical landmarks, sites or monuments. These areas shall be subject to periodic re-assessment whenever necessary.

For purposes of this Act, the following shall be the responsibilities of cultural agencies in the categorization of cultural property:

(a) The Cultural Center of the Philippines shall be responsible for significant cultural property pertaining to the performing arts;

(b) The National Archives of the Philippines shall be responsible for significant archival materials;

(c) The National Library shall be responsible for rare and significant contemporary Philippine books, manuscripts such as, but not limited to, presidential papers, periodicals, newspapers, singly or in collection, and libraries and electronic records;

(d) The National Historical Institute shall be responsible for significant movable and immovable cultural property that pertains to Philippine history, heroes and the conservation of historical artifacts;

(e) The National Museum shall be responsible for significant movable and immovable cultural and natural property pertaining to collections of fine arts, archaeology, anthropology, botany, geology, zoology and astronomy, including its conservation aspect; and

(f) The Komisyon sa Wikang Filipino shall be responsible for the dissemination development, and the promotion of the Filipino national language and the conservation of ethnic languages.

SEC. 32. Institutional Linkages of the National Cultural Agencies. – The cultural agencies and other national government agencies, as listed below, shall consult, coordinate and work closely with the Commission in the implementation of their respective programs/projects in the context of this Act. Furthermore, the Commission may link up with other agencies and institutions, as it may deem appropriate, as a way of dealing with conservation in a holistic manner:

- (a) The Department of Tourism and its attached agencies which shall be responsible for cultural education among tourism services, and protection of cultural properties supplemental to the jurisdiction of the cultural agencies as defined in this Act. The implementation and creation of a tourism master plan shall be consistent with this Act;
- (b) The Intramuros Administration which shall be responsible for the restoration and administration of the development in Intramuros;
- (c) The National Parks Development Committee as an attached agency of the Department of Tourism which shall be responsible in supervising the development (beautification, preservation and maintenance) of the Quezon Memorial, Fort Santiago, Luneta, Paco Park, Pook ni Maria Makiling and other national parks and satellite projects;
- (d) The Department of Education which shall be responsible in instituting the governance of basic education act, and the conservation and restoration of its built heritage such as the significant Gabaldon school buildings as determined by the National Historical Institute;
- (e) The Department of Public Works and Highways which shall be responsible in undertaking major infrastructure projects specifically in the planning, design, construction, and maintenance of national roads and bridges as they impact on heritage structures or aspects of heritage conservation;
- (f) The National Commission on Indigenous Peoples, in behalf of the country's indigenous cultural communities, which shall coordinate with the national agencies on matters pertaining to cultural properties under its jurisdiction;
- (g) The Department of Environment and Natural Resources which shall be responsible for the establishment and management of the National Integrated Protected Areas System and the conservation of wildlife resources, including cave and cave resources and which shall coordinate with the National Commission on Indigenous Peoples, the conservation of natural resources that are cultural sanctuaries of indigenous peoples;
- (h) The Department of the Interior and Local Government which shall coordinate with the national cultural agencies on matters pertaining to cultural properties under its jurisdiction, and ensure that the provisions of this Act is properly executed by the local government unit;
- (i) The Office on Muslim Affairs which shall coordinate with the national cultural agencies on matters pertaining to cultural properties under its jurisdiction;
- (j) The UNESCO National Commission of the Philippines which shall be responsible for providing the liaison between the cultural agencies of the Philippines and the UNESCO as well as assist the national cultural agencies in implementing the agreements and conventions adopted by the UNESCO of which the Philippines has ratified or is in the process of ratification;
- (k) The Housing and Land Use Regulatory Board which shall coordinate with the local government units and the Commission on matters pertaining to the establishment and maintenance of heritage zones;
- (l) The Autonomous Region in Muslim Mindanao and the Cordillera Administrative Region which shall coordinate with the national cultural agencies on matters pertaining to cultural properties under their respective jurisdictions; and
- (m) The Office of the Special Envoy on Transnational Crimes which shall have the oversight and operational capacity to go after illicitly trafficked and stolen cultural treasures.

SEC. 33. Incorporation of Cultural Property Programs in Local Government Units' Budgets. – The local government units are encouraged to incorporate programs and budgets for the conservation and preservation of cultural property in their environmental, educational and cultural activities.

SEC. 34. Training Programs. – The Commission, in coordination with the appropriate cultural agencies, shall provide general training programs on conservation to the local government units which have established cultural heritage programs and projects in their localities.

ARTICLE IX CULTURAL PROPERTY INCENTIVES PROGRAM

SEC. 35. Tax Exemption on Donations. – All donations in any form to the Commission and its affiliated cultural agencies shall be exempt from the donor's tax and the same shall be considered as allowable deduction from the gross income in the computation of the income tax of the donor, in accordance with the provisions of the National Internal Revenue Code of 1997, as amended.

SEC. 36. National Heritage Resource Assistance Program. – The Commission may provide financial assistance in the form of a grant to historic, archaeological, architectural, artistic organizations for conservation or research on cultural property. No grant made pursuant to this Act shall be treated as taxable income.

SEC. 37. Awards and Citations. – To encourage preservation of the national heritage, the Commission shall establish an annual conservation recognition program under which monetary prizes, awards and citations will be given by the President of the Philippines, upon the recommendation of the Commission, for special achievements and important contributions and services in the area of heritage preservation and conservation efforts.

ARTICLE X CULTURAL EDUCATION

SEC. 38. Incorporation of National Cultural Treasures and Important Cultural Property in the Basic Education System. – Within one (1) year from the effectivity of this Act, the Department of Education, in coordination with the Commission's Philippine Cultural Education Program, shall formulate the cultural heritage education programs both for local and overseas Filipinos to be incorporated into the formal, alternative and informal education, with emphasis on the protection, conservation and preservation of cultural heritage property.

The Philippine Registry of Cultural Property shall likewise be incorporated into the formal, alternative and informal education by the provincial and local governments.

SEC. 39. Cultural Heritage Education Program. – Within one (1) year from the effectivity of this Act, the Department of Education, the Technical Education and Skills Development Authority and the Commission on Higher Education, in consultation with the Commission, shall set forth in its teaching programs nationwide the following cultural heritage education programs with emphasis at the provincial city and municipal levels:

- (a) Protection, conservation and preservation of cultural heritage properties;
- (b) Instructional materials in print, film and broadcast media on the cultural and historical significance of cultural properties; and
- (c) Visitation, public accessibility and information dissemination on designated local cultural properties.

SEC. 40. Public Accessibility. – Access to national historical landmarks, monuments and sites, whether designated as national cultural treasures or important cultural property by the general public for visitation and information, and by government representatives for inspection, shall not be hindered except on reasonable cause. Fees, as prescribed by the cultural agency concerned, may in appropriate cases be charged to defray the cost of conservation, inclusive of general maintenance and upkeep. In the case of privately-owned monuments and sites, the National Historical Institute or the National Museum shall arrange with the owners the schedules of visits and regular inspection.

ARTICLE XI CULTURAL HERITAGE WORKERS' INCENTIVES PROGRAM

SEC. 41. Cultural Heritage Workers' Incentives. – The national cultural agencies, in coordination with the Commission on Higher Education, shall initiate scholarships, educational training programs and other measures

to protect the well-being of curators, conservators, authenticators, cultural researchers or educators, historians, librarians, archivists and valuers/appraisers of cultural property. Such cultural workers shall be given grants, incentives and scholarships upon the endorsement by the head of the appropriate cultural agency:

(a) Program for Cultural Heritage Workers. – Within ninety (90) days from the effectivity of this Act, the Commission shall come up with the following:

- (1) An active roster of authenticators and valuers/appraisers;
- (2) An education and training plan for conservators, authenticators, valuers/appraisers and other conservation-related workers; and
- (3) A general training plan on conservation for local government units.

(b) Application of Scientific Career Merit System. – Cultural heritage workers in the civil service with a doctorate, master of science, or master of arts degree in fields related to cultural heritage promotion and conservation shall be given the rank and benefits of scientists subject to qualifying standards equivalent to those prescribed in the scientific career merit system of the government.

A cultural heritage worker involved in science and technology in government agencies shall be eligible for the benefits under Republic Act No. 8439, or the “Magna Carta for Scientists, Engineers, Researchers and Other S & T Personnel in the Government”. The Commission shall likewise establish a merit award system for non-civil service cultural heritage workers.

ARTICLE XII SENTRO RIZAL

SEC. 42. Creation of Sentro Rizal. – There is hereby created and established a Sentro Rizal whose main purpose is the promotion of Philippine arts, culture and language throughout the world.

SEC. 43. Overseas Branches or Offices of Sentro Rizal. – Sentro Rizal shall have branches or offices in countries where there are children of overseas Filipino workers who need to be educated about their roots, as well as developed countries where there are large Filipino communities.

The office or branch shall be repository, inter alia, of the following materials on Philippine arts, culture and language: books, digital video discs, compact discs, films, magazines, artworks, tourism promotion materials, information materials, etc. All these shall be made available to the public, both Filipino and foreign.

SEC. 44. Coordination and Supervision with Philippine Schools. – The Sentro Rizal shall coordinate and supervise the Philippine schools for Filipino children overseas.

SEC. 45. Services Offered. – The Sentro Rizal shall offer Filipino language courses for children and adults, as well as exhibits, small concerts, poetry reading, Philippine cuisine lessons in all Sentro Rizal branches.

SEC. 46. Provision of Tourism, Trade and Investment Materials to the Sentro Rizal. – The Department of Tourism, as well as the Department of Education, the National Commission on Culture and the Arts, the Commission on Higher Education, the National Historical Institute, the National Archives, the National Library, and the Cultural Center of the Philippines, shall provide tourism promotion materials to the Sentro Rizal overseas branches. In the same manner, the Department of Trade and Industry shall also provide trade and investments materials.

SEC. 47. Appropriations. – The amount of One hundred million pesos (P 100,000,000.00) necessary to carry out the provisions of this Act shall be appropriated immediately to be generated from whatever source that are available in the National Treasury.

ARTICLE XIII PENAL PROVISIONS

SEC. 48. *Prohibited Acts.* – To the extent that the offense is not punishable by a higher punishment under another provision of law, violations of this Act may be made by whoever intentionally:

- (a) Destroys, demolishes, mutilates or damages any world heritage site, national cultural treasures, important cultural property and archaeological and anthropological sites;
- (b) Modifies, alters, or destroys the original features of or undertakes construction or real estate development in any national shrine, monument, landmark and other historic edifices and structures, declared, classified, and marked by the National Historical Institute as such, without the prior written permission from the Commission. This includes the designated security of buffer zone, extending five (5) meters from the visible perimeter of the monument or site;
- (c) Explores, excavates or undertakes diggings for the purpose of obtaining materials of cultural historical value without prior written authority from the National Museum. No excavation or diggings shall be permitted without the supervision of a certified archaeologist;
- (d) Appropriates excavation finds contrary to the provisions of the New Civil Code and other pertinent laws;
- (e) Imports, sells, distributes, procures, acquires, or exports cultural property stolen, or otherwise lost against the will of the lawful owner;
- (f) Illicitly exports cultural property listed in the Philippine Registry of Cultural Property or those that may be categorized as such upon visitation or incorrectly declares the same during transit; and
- (g) Deals in cultural property without proper registration and license issued by the cultural agency concerned.

SEC. 49. *Penal Provisions.* – Upon conviction, the offender shall be subject to a fine of not less than Two hundred thousand pesos (P 200,000.00) or imprisonment for a term of not less than ten (10) years, or both, upon the discretion of the court: Provided, That any cultural property attempted to be concealed from registration or those intended to be encumbered or excavated in violation of this Act shall be summarily confiscated and forfeited in favor of the Commission: Provided, further, That if the violation is committed by a juridical person, the president, manager, representative, director, agent or employee of the said juridical person responsible for the act shall also be liable for the penalties provided herein: Provided, furthermore, That if the acts are committed by dealers, they shall suffer, in addition to the penalties provided herein, the automatic revocation of their license to operate: Provided, finally, That if the offender is an alien, he/she shall be placed under the custody of the Bureau of Immigration for the appropriate proceedings under this Act and shall be summarily deported after serving his/her sentence.

Heads of departments, commissions, bureaus, agencies or offices, officers and/or agents found to have intentionally failed to perform their required duty as prescribed by the deputization order under Section 28 of this Act shall be liable for nonfeasance and shall be penalized in accordance with applicable laws.

In the offence involves the nonregistration of a cultural property such as those referred to in Section 14, and the nonregistration occurs upon or after proper notification by the Commission or the cultural agency concerned, the offender shall be subject to a fine of not less than Ten thousand pesos (P 10,000.00) but not more than One hundred thousand pesos (P 100,000.00).

The concerned head of agency, officer and/or employee of the government entities mentioned in Section 31 shall be held liable for failure to consult and coordinate with the Commission for the damage to the cultural property resulting from the implementation of the entity's program/project, and shall be meted the penalty mentioned in the first paragraph of this section: Provided, That the offender/s shall likewise be asked to pay for the repair or rebuilding of what has been damaged.

ARTICLE XIV ENDOWMENT

SEC. 50. *National Endowment for Culture and the Arts.* – The sum of Five hundred million pesos (P

500,000,000.00) shall be contributed by the Philippine Amusement and Gaming Corporation (PAGCOR) and/or General Appropriations at the minimum rate of One hundred million pesos (P 100,000,000.00) per year for five (5) years towards the establishment of a National Endowment for Culture and the Arts. Said amount shall be kept separate and deposited in a special account in the Bureau of Treasury specifically earmarked for culture and the arts.

ARTICLE XV FINAL PROVISIONS

SEC. 51. Implementing Rules and Regulations. – The Commission, in consultation with other government agencies mentioned in this Act, shall promulgate the implementing rules and regulations within ninety (90) days after the effectivity of this Act.

SEC. 52. Repealing Clause. – Pertinent provisions of Republic Act No. 7356, the “Law Creating the National Commission for Culture and the Arts”; Republic Act No. 8492, the “National Museum Act of 1998”; Republic Act No. 9072, the “National Caves and Cave Resources Management and Protection Act”; Republic Act No. 7942, the “Philippine Mining Act of 1995”; and all other laws, presidential decrees, executive orders and rules and regulations inconsistent with the provisions of this Act are hereby repealed or modified accordingly.

SEC. 53. Separability Clause. – Any portion or provision of this Act that may be declared unconstitutional shall not have the effect of nullifying other portions or provisions hereof as long as such remaining provisions can still subsist and be given effect.

SEC. 54. Effectivity Clause. – This Act shall take effect fifteen (15) days after its publication in at least two (2) newspapers of general circulation.

Approved

(signature)
PROSPERO C. NOGRALES
Speaker of the House of Representatives

(signature)
JUAN PONCE ENRILE
President of the Senate

This Act which is a consolidation of Senate Bill No. 3014 and House Bill No. 6733 was finally passed by the Senate and the House of Representatives on December 14, 2009 and December 16, 2009, respectively.

(signature)
MARILYN B. BARUA-YAP
Secretary General
House of Representatives

(signature)
EMMA LIRIO-REYES
Secretary of the Senate

Approved: March 26, 2010

(signature)
GLORIA MACAPAGAL-ARROYO
President of the Philippines

**IMPLEMENTING RULES AND REGULATIONS
 OF
 REPUBLIC ACT NO. 10066,
 AN ACT PROVIDING FOR THE PROTECTION AND CONSERVATION OF THE NATIONAL CULTURAL
 HERITAGE, STRENGTHENING THE NATIONAL COMMISSION FOR CULTURE AND THE ARTS
 (NCCA) AND ITS AFFILIATED CULTURAL AGENCIES, AND FOR OTHER PURPOSES**

RULE I TITLE, PURPOSE AND CONSTRUCTION

Section 1. Short Title. – These rules shall be known as the “Implementing Rules and Regulations of Republic Act No. 10066 otherwise known as the National Cultural Heritage Act of 2009.”

Section 2. Purpose. – These Rules are promulgated to prescribe the procedures and guidelines for the implementation of RA No. 10066 in order to facilitate compliance therewith and to achieve the objectives thereof.

Section 3. Construction. – These Rules shall be construed and applied in accordance with, and in furtherance of the policies and objectives of the law. In case of conflict or ambiguity, which may arise in the implementation of these Rules, the National Commission for Culture and the Arts shall issue the necessary clarification. In case of doubt, the same shall be construed liberally and in favor of the Constitutional directives to foster preservation, enrichment and dynamic evolution of a Filipino culture.

RULE II DECLARATION OF POLICIES AND OBJECTIVES

Section 4. Declaration of Policies. – In line with the Constitution, the following policies shall guide these rules:

Section 4.1. The State shall foster the preservation, enrichment, and dynamic evolution of a Filipino national culture based on the principle of unity in diversity in a climate of free artistic and intellectual expression (Sec. 14, Art. XIV Constitution)

Section 4.2. Arts and letters shall enjoy the patronage of the State. The State shall conserve, promote, and popularize the nation’s historical and cultural heritage and resources, as well as artistic creations. (Sec. 15, supra)

Section 4.3. All the country’s artistic and historic wealth constitutes the cultural treasure of the nation and shall be under the protection of the State, which may regulate its disposition. (Sec. 16, supra)

Section 4.4. The state shall recognize, respect, and protect the rights of indigenous cultural communities to preserve and develop their cultures, traditions, and institutions. It shall consider these rights in the formulation of national plans and policies. (sec. 17, supra)

Section 5. Objectives. – In pursuit of cultural preservation as a strategy for maintaining Filipino identity, these rules shall pursue the following objectives:

Section 5.1. Protect, preserve, conserve and promote the nation’s cultural heritage, its property and histories, and safeguard the ethnicity of local communities;

Section 5.2. Establish and strengthen cultural institutions; and,

Section 5.3. Protect cultural workers and ensure their professional development and well-being.

The State shall likewise endeavor to create a balanced atmosphere where the historic past co-exists in harmony with modern society. It shall approach the problem of conservation in an integrated and holistic manner, cutting across all relevant disciplines and technologies. The State shall further administer the heritage resources in a spirit of stewardship for the inspiration and benefit of the present and future generations.

Rule III DEFINITION OF TERMS

Section 6. Definition of Terms. – for purposes of this Act, the following terms shall be defined as follows:

- (a) **“Adaptive Re-use”** shall refer to the utilization of buildings, other built structures and sites of value for purposes other than that for which they were intended originally, in order to conserve the site, their engineering integrity and authenticity of design.
- (b) **“Anthropological Area”** shall refer to any place where studies of specific ethno-linguistic groups are undertaken, the properties of which are of value to cultural heritage.
- (c) **“Antique”** shall refer to a cultural property found locally which is one hundred (100) years in age, more or less, the production of which has ceased.
- (d) **“Archeological Area”** shall refer to any place whether above or underground, underwater or at sea level, containing fossils, artifacts and other cultural, geological, botanical, zoological materials which depict and document culturally relevant paleontological, prehistoric and/or historic events.
- (e) **“Archive” or “archives”** shall refer to public and private records in any format which have been selected for permanent preservation because of their evidential, historical information value; otherwise known as archival materials collections or archival holdings; the place (building/room/storage area) where archival materials are kept and preserved; and an organization or agency or part thereof whose main responsibility is to appraise, arrange, describe, conserve, promote and make archival materials available for reference and research, also known as archival agency.
- (f) **“Built heritage”** shall refer to architectural and engineering structures, such as but not limited to bridges, government buildings, ancestral houses, places of worship, traditional dwellings, military installations, train stations, lighthouses, small ports, city and streetscapes, educational technological and industrial complexes, and their settings, and landscapes with notable historical and cultural significance.
- (g) **“Collector”** shall refer to any person who or institution that acquires cultural property for purposes other than sale.
- (h) **“Commission”** shall refer to the National Commission for Culture and the Arts (NCCA).
- (i) **“Conservation”** shall refer to all the processes and measures of maintaining the cultural significance of a cultural property, including but not limited to, preservation, restoration, reconstruction, protection, adaptive re-use or any combination thereof.
- (j) **“Cultural agencies”** shall refer to any of the following national government agencies with their specific areas of responsibility: National Museum (cultural property), the National Library (books); National Historical Commission of the Philippines (Philippine history), the National Archives of the Philippines (documents), the Cultural Center of the Philippines (culture and the arts) and Komisyon ng Wikang Filipino (language).
- (k) **“Cultural Education”** shall refer to the teaching and learning of cultural concepts and processes.
- (l) **“Cultural Heritage”** shall refer to the totality of cultural property preserved and developed through time and passed on to posterity.
- (m) **“Cultural Heritage worker”** shall refer to an individual undertaking cultural heritage work.
- (n) **“Cultural Institution”** shall refer to entities primarily engaged in cultural work.
- (o) **“Cultural Property”** shall refer to all products of human creativity by which a people and a nation reveal their identity, including architecture and sites or human activity [churches, mosques and other places of religious worship, schools] and natural history specimens and sites, whether public or privately owned, movable or immovable and tangible or intangible.
- (p) **“Dealers”** shall refer to natural and juridical persons who acquire cultural property for the purpose of engaging in the acquisition and disposition of the same.
- (q) **“Heritage Zone”** shall refer to historical, anthropological, archeological, artistic, geographical areas, center district, and settings that are culturally significant to the country, as declared by the National Museum and/or the National Historical Commission of the Philippines.
- (r) **“History”** shall refer to a written record of past events relating to Philippine history.

- (s) “Historical Landmarks”** shall refer to sites or structures that are associated with events or achievements significant to Philippine history as declared by the National Historical Commission of the Philippines.
- (t) “Historical Monuments”** shall refer to structures that honor illustrious persons or commemorate events of historical value as declared by the National Historical Commission of the Philippines.
- (u) “Historical Shrines”** shall refer to historical sites or structures hallowed and revered for their history or association as declared by the National Historical Commission of the Philippines.
- (v) “Historical Street Name”** shall refer to a street name which has been in existence for at least fifty (50) years and over time has been considered historic.
- (w) “Important Cultural Property” (ICP)** shall refer to a cultural property having exceptional cultural, artistic, and historical significance to the Philippines as shall be determined by the National Museum, the National Historical Commission of the Philippines, the National Library of the Philippines and/or the National Archives of the Philippines.
- (x) “Incunabula”** printed works produced by the native press when the art of printing in a particular country or locality is still in infancy. In the Philippines, historians and bibliographers often refers to the years 1593 to 1640 our incunabula period.
- (y) “Intangible Cultural Heritage”** shall refer to the practices, representations, expressions, knowledge, skills, as well as instruments, objects and artifacts associated therewith, that communities, groups and individuals recognize as part of their cultural heritage, such as: (1) oral traditions, usages, customs, languages and other expressions; (2) performing arts; (3) social practices, religious rites, rituals, culinary traditions and festive events; (4) knowledge and practices concerning nature and the universe, worship and (5) traditional craftsmanship.
- (z) “Intangible cultural property”** shall refer to the peoples’ learned processes along with knowledge, skills and creativity that inform and are developed by them, the products and other manifestations that they create and the resources, spaces and other aspects of social and natural context necessary for their sustainability.
- (aa) “Language”** refers to the codes and symbols used by a particular speech community in both written and spoken form to facilitate the conduct of any discourse that contributes to the smooth functioning of society.
- (bb) “Library”** shall refer to an institution where the collection of books, manuscripts, computerized information and other materials are organized to provide physical, bibliographic, and/or intellectual access to the public, with a librarian that is trained to provide services and programs related to the information needs of its clientele.
- (cc) “Manuscripts”** works prepared by hand including handwritten or typescript drafts of the publication papers or works not otherwise in multiple copies.
- (dd) “Museum”** shall refer to a permanent institution that researches, acquires, conserves, communicates and exhibits the material evidence of humans and their environment for purposes of education or leisure.
- (ee) “National Cultural Treasure”** shall refer to a unique cultural property found locally, possessing outstanding historical, cultural, artistic and/or scientific value which is highly significant and important to the country and officially declared as such by the pertinent cultural agency.
- (ff) “Nationally significant”** shall refer to historical, aesthetic, scientific, technical, social and/or spiritual values that unify the nation by a deep sense of pride in their various yet common identities, cultural heritage and national patrimony.
- (gg) “Natural Property of Cultural Significance”** shall refer to areas possessing outstanding ecosystems with flora and fauna with national scientific importance under the National Integrated Protected Areas System.
- (hh) “NCCA Portal Cultural Databank”** refers to the specific domain in the Commission’s intranet for cultural information that is accessed only internally with control and confidentiality. It includes the Philippine Registry of Cultural Property (PRECUP).
- (ii) “Pre-history”** refers to the period of human existence and activities before the introduction of the forms of writing.
- (jj) “Presidential Papers/Collections”** contains published and unpublished collection on Philippine presidency from Emilio Aguinaldo to present. It also includes photographs, books collections, manuscripts, personal papers and records as well as digital resources.
- (kk) “Rarebooks”** all Filipiniana books printed or publish before 1945. It also includes original manuscripts, exceptional collections, and other publications of historical importance.
- (ll) “Records”** recorded information produced or received in the initiation, conduct or completion of an

institutional or individual activity and that comprises content, context and structure sufficient to provide evidence of the activity.

(mm) “Registry” shall refer to the Philippine Registry of Cultural Property (PRECUP), which is the registry of all cultural property of the country deemed significant to cultural heritage.

(nn) “Restoration” shall refer to the action taken or the technical intervention to correct deterioration and alterations.

(oo) “Special Collections” materials, within a library, which are “special” in nature which are typically stored because they are unusually valuable, rare, and unique. It also includes rare books, archives, and collected manuscripts.

(pp) “Tangible cultural property” shall refer to cultural property with historical, archival, anthropological, archeological artistic, and/or architectural value and with exceptional or traditional production, whether of Philippine origin or not, including antiques and natural history specimens with significant value.

Rule IV CULTURAL PROPERTY

Section 7. Categories. – The Cultural Property of the country whether public or privately owned, movable or immovable, and tangible or intangible shall be categorized as follows:

The following shall be declared as Grade I level:

- (a) World Heritage Sites;
- (b) National Cultural Treasures;
- (c) National Historical Landmarks;
- (d) National Historical Shrines; and,
- (e) National Historical Monuments.

The following shall be declared as Grade II level:

- (a) Important Cultural Properties;

Section 7.1. Grade III cultural property. – All other cultural property in the Registry of Cultural Property not declared as Grades I or II shall be Grade III cultural property deemed-Important Cultural Property, unless otherwise delisted.

Section 7.2. Uncategorized property. – Undeclared property not falling under the presumption of Important Cultural Property, but contains characteristics that will qualify them as such shall be registered in the Philippine Registry of Cultural Property.

Section 8. Cultural Property Considered Important Cultural Property. – For purposes of protecting a cultural property against exportation, modification or demolition, the following works shall be considered Important Cultural Property:

Section 8.1. Works by a Manlilikha ng Bayan. – Works by deceased Manlilikha ng Bayan awardees shall be considered Important Cultural Property, unless declared or its presumption removed by the Commission.

Section 8.2. Works by National Artists. – Works by deceased National Artists shall be considered Important Cultural Property, unless declared or its presumption removed by the Commission.

Section 8.3. Archeological, traditional, ethnographic material. – Unless declared or its presumption removed by the National Museum, all archeological and traditional ethnographic materials shall be considered Important Cultural Property.

Section 8.4. Works and Structures. – Unless declared or its presumption removed by the National Historical Commission of the Philippines, works of national heroes, movable or immovable structures marked by

the NHCP or any of its predecessor agencies or structures at least fifty (50) years old, shall be considered Important Cultural Property.

Section 8.5. Archival materials or documents. – Unless declared or its presumption removed by the National Archives, archival materials or documents at least fifty (50) years old shall be considered Important Cultural Property.

Section 8.6. Rarebooks and Incunabula. – Unless declared or its presumption removed by the National Library of the Philippines, rarebooks, special collections, and incunabula shall be considered Important Cultural Property.

Section 9. World Heritage Sites (WHS). – The Commission, together with either the National Museum or the NHCP shall closely collaborate with United Nations Educational Scientific and Cultural Organization (UNESCO) National Commission of the Philippines in ensuring the conservation and management of world heritage sites of cultural and mixed sites category, in the Philippines.

Section 9.1. Standards of conservation for World Heritage Sites. – The WHS shall be subject to the highest standards of conservation and management prescribed by the WH Convention, its Operational Guidelines and the WH Convention, its Operational Guidelines and the WH Committee, to ensure the safeguarding and sustainability of its Outstanding Universal Values over time. In no manner shall the Outstanding Universal Value, its authenticity and integrity be allowed to be compromised.

Section 9.2. Monitoring of World Heritage Sites. – The Commission shall continuously monitor the condition of the sites and shall, with the National Museum and the NHCP as appropriate, collaborate with the site managers and the Local Government Units where the WHS is located to ensure the safeguarding of the Outstanding Universal Value, the integrity and authenticity of the WHS.

Section 9.3. Referral to penal provisions. – Should an agency, local or otherwise, fail to ensure the authenticity and integrity of the WHS, the Commission shall enforce the penal provisions of this Act.

Section 9.4. Conservation Management Plan. – The Commission shall ensure that all WHS have a Conservation Management Plan. This Management Plan shall be prepared according to the requirements of WH Convention and its Operational Guidelines and shall contain provisions for protection, management and conservation of the WHS including cartographic materials that clearly show its boundaries and allowed zones for protection.

The Management Plan shall be implemented by all sectors involved in the conservation, management and protection of the WHS including other non-government stakeholders of the property.

The Conservation Management Plan shall be subject to regular evaluation and review by the Commission.

Section 9.5. Technical assistance. – The Commission, the National Museum or the NHCP, as appropriate, may provide technical assistance to stakeholders and local government units with property in the tentative list for the preparation of the necessary documents and dossier required for inscription in the UNESCO World Heritage List.

Section 10. Privileges of Cultural Property. – All cultural properties declared as National Cultural Treasures and National Historical Landmarks shall be entitled to the following privileges:

- (a) Priority government funding for protection, conservation and restoration;
- (b) Incentives for private support of conservation and restoration through the Commission's Conservation Incentive Program for National Cultural treasures;
- (c) An official Heritage Marker placed by the cultural agency concerned indicating that the immovable

cultural property has been identified as national cultural treasures; and/or national historical landmarks, sites or monuments; and,

(d) In times of armed conflict, natural disasters, and other exceptional events that endanger the cultural heritage of the country, all World Heritage Sites, National Cultural Treasures or National Historical Landmarks, sites or monuments shall be given utmost priority protection by the Government.

All cultural property declared as Important Cultural Property may also receive government funding for its protection, conservation, and restoration. An official Heritage Marker may likewise be placed on an immovable cultural property to identify the same as important cultural property.

Section 11. Procedure for Declaration, De-Listing and Lifting of National Cultural Treasures, Important Cultural Property or Property Deemed Important Cultural Property. – The procedure in declaring as well as in delisting a National Cultural Property or an Important Cultural Property shall be as follows:

Section 11.1. Filing of the petition. – A declaration or a lifting of cultural property as National Cultural Treasure or Important Cultural Property shall commence upon the filing of a verified petition by the owner, stakeholder or any interested person with the Commission, which shall issue temporary remedies, if necessary to protect a site prior to declaration, after which it shall refer the matter to the appropriate cultural agency.

Upon verification of the suitability of the property as a national cultural treasure or an important cultural property, the cultural agency concerned shall send notice of hearing to the owner and stakeholders. Stakeholders, including but not limited to local government units, local culture and arts council, local tourism councils, non-government conservation organizations, and schools, may be allowed to file their support or opposition to the petition;

The owner and/or other stakeholders shall file their position paper within fifteen (15) days from receipt of the notice of hearing, furnishing all the parties, including the appropriate cultural agency, with such position paper. Extensions may be allowed, but in no case shall it exceed more than thirty (30) days; and

The petitioner/stakeholder shall give their answer within fifteen (15) days upon receipt of any position paper. Thereafter, no further submissions shall be allowed.

The appropriate cultural agency shall have a maximum of ninety (90) days from the deadline of the submission of all the answers within which to submit its resolutions and render its decision on the application.

Section 11.2. Filing fees. – The Commission may charge a fee for petitions.

Section 12. Right of First Refusal on the Sale of National Cultural Treasures, Important Cultural Properties, National Historical Landmarks, declared sites and structures. – The appropriate cultural agency shall be given the right of first refusal in the purchase of cultural property declared as national cultural treasures. Prior to the finality of the sale, the appropriate cultural agency may likewise match any offer made for the purchase of national cultural property.

Section 12.1. Notice in writing. – Any owner of a National Cultural Treasure shall notify in writing the appropriate cultural agency when it has an agreement to sell said National Cultural Treasure and the terms and considerations thereof.

Section 12.2. Period for Exercise of the Right. – The owner shall give the appropriate cultural agency ninety (90) days from notice in which to match the consideration for the purchase of the said National Cultural property.

Section 13. Licensing of Dealers of Cultural Property. – All dealers of cultural properties shall secure a license to operate as such from the National Museum. The National Museum shall continue the licensing of dealers, agents and exporters of cultural properties as well as the renewal of their licenses pursuant to the existing rules and regulations.

All agents of dealers and exporters of cultural properties shall also secure a license from the National Museum in accordance with the existing policies of the National Museum.

Section 14. Dealings of Cultural Property. – No cultural property shall be sold, resold, or taken out of the country without first securing a clearance from the cultural agency concerned, particularly the National Museum in the case of a Permit to Export. In case the property shall be taken out of the country, it shall solely be for the purpose of scientific scrutiny or exhibit, repair, visual arts cleaning and restoration, except for those cultural property that are considered fine arts, works of National Artists other than for Architecture, and those works that have been produced by living Manlilikha ng Bayan awardees and artifacts, archeological, traditional and ethnographic materials classified as Grade III.

(a) **Sale or Resale of Cultural Property** – The sale or resale of a cultural property, subject to the right of first refusal in Section 12 hereof shall also require the following:

1. National Cultural Treasures shall not change ownership, except by inheritance or by sale duly approved by the concerned cultural agency; provided, however, that it may not be taken out of the country for reasons of inheritance or sale.
2. National Cultural Treasures may be taken out of the country only with a written permit from the concerned cultural agency and only for purposes of exhibition or for scientific scrutiny but shall be returned immediately after such exhibition or study; provided, however, that necessary safeguards have been duly complied with, as required by the concerned cultural agency.

(b) **Purposes for which a Cultural property Grade I and II may be taken out of the country** – In case the property shall be taken out of the country, it shall solely be for the purpose of scientific scrutiny or exhibit, and shall meet the following requirements:

1. The applicant must execute an affidavit that the cultural property is not for sale and will guarantee its return to the country after its event;
2. To guarantee such return, the said cultural property shall be covered by a surety bond amounting to 100% of the appraised value. The surety bond shall be issued by a reputable insurance company;
3. In case the exhibit of the cultural property is extended, prior approval by the National Museum shall be secured;
4. The bond shall be forfeited when the National Museum is not informed of its extension.

No licensed agent, dealer or exporter shall engage in the sale of cultural properties not duly stamped or marked by the National Museum or concerned agency;

Cultural properties in transit within the Philippines shall be covered by a conduction invoice by the seller thereof indicating his Residence Certificate and Tax Account Number;

Within one hundred and twenty (120) days after the approval of these rules and regulations all cultural properties placed on sale shall be duly registered and stamped by the National Museum or concerned agency;

Transfer, change of ownership or sale of National Cultural Treasure and Important Cultural Properties shall be reported to the Commission or the concerned agency by the transferee within thirty (30) days from the conclusion of such transaction.

(c) **Intangible cultural property.** – The Commission shall monitor and administer the protection of intangible cultural property. The material recordings of intangible property shall be closely monitored. Recordings of intangibles save for indigenous design shall require written permits from the Commission when taken out of the country.

RULE V HERITAGE ZONES / DISTRICTS

Section 15. Designation of Heritage Zones. – The National Historical Commission of the Philippines, the National Museum, in consultation with the Housing and Land Use Regulatory Board or other concerned agencies shall designate heritage zones to protect the historical and cultural integrity of a geographical area.

Section 15.1. Declared Heritage Zones. – shall be subject to the environmental impact assessment laws, rules and regulations of the DENR and shall henceforth be considered a culturally sensitive area for purposes of complying with the requisites of the said laws, rules and regulations.

Section 15.2. Petition for declaration of Heritage Zones. – Local government units may apply with the NHCP or National Museum for the designation of a heritage zone in its jurisdiction.

Section 16. Maintenance of Heritage Zones. – A Heritage Zone shall be maintained by the local government unit concerned, in close coordination with the appropriate cultural agency. The local government unit having jurisdiction over a declared Heritage Zone shall have the following guidelines:

- (a) Implementation of adaptive re-use of cultural property;
- (b) Appearance of streets, parks, monuments, buildings, and natural bodies of water, canals, paths and Barangays within a locality shall be maintained as close to their appearance at the time the area was of most importance to Philippine history as determined by the National Historical Commission of the Philippines; and,
- (c) Local government units shall document and sustain all socio-cultural practices such as but not limited to traditional celebrations, historical battles, recreation of customs, and the re-enactment of battles and other local customs that are unique to a locality.

RULE VI REGISTRATION AND CONSERVATION OF CULTURAL PROPERTY

Section 17. Establishment of a Philippine Registry of Cultural Property (PRECUP). – All cultural property of the country deemed important to cultural heritage shall be registered in the Philippine Registry of Cultural Property. The Commission, through the appropriate cultural agencies and local government units shall establish and maintain this Registry within three (3) years from the effectivity of this Act.

Section 17.1. Inventory by Cultural Agencies. – All cultural agencies concerned shall individually maintain and come up with an inventory, evaluation and documentation of all cultural property they have declared and shall submit the same to the Commission.

Section 17.2. Annotation of Titles of Immovable Cultural Properties – For property declared as Immovable Cultural Property, the appropriate cultural agency shall, after registration, give a copy of the said property to the Registry of Deeds having jurisdiction over the said property, for annotation on the land titles covering said immovable property.

Section 17.3. Inventory by LGUs – Local government units, through their cultural offices, shall likewise maintain an inventory of cultural property under its jurisdiction and shall furnish the Commission a copy of the same.

Section 17.4. Confidentiality – Information on registered cultural properties owned by private individuals shall remain confidential and may be given only upon prior consent of the private owner. The Commission shall operate the Registry in the NCCA portal cultural databank.

Section 17.5. Public Accessibility – The Commission shall maintain a separate list for the public stating the categories and cultural properties thereunder for public access that will not indicate ownership and location of such cultural properties.

Section 18. Conservation of Cultural Property. – All intervention works and measures on conservation of National Cultural Treasures, Important Cultural Property, as well as National Historical Landmarks, sites, monuments, and structures previously marked by the National Museum and/or the National Historical Commission of the Philippines before the implementation of this Act shall be undertaken only upon prior approval of the Commission through the appropriate cultural agency which shall supervise the same.

The Commission shall approve only those method and materials that strictly adhere to the accepted international standards of conservation.

Section 19. Documentation and Preservation of Traditional and Contemporary Arts. – Local government units shall document traditional and contemporary arts and crafts, including their processes and makers, and sustain the sources of their raw materials within their jurisdiction. The local government units shall encourage and sustain traditional arts and crafts as active and viable sources of income for the community.

The Commission, the Department of Trade and Industry, the Department of Tourism and other government agencies involved directly or indirectly in the production of goods shall assist the local government units in protecting their traditional and contemporary arts and crafts making them viable for current and future markets, with a view to encouraging and promoting the unique heritage and identities of the said communities.

The local government unit concerned shall submit an annual inventory of these documentations to the Commission, which will be included in the Philippine Registry of Cultural Property.

Section 20. Systematic Research in Natural History. – The National Museum shall have the authority to collect, maintain and develop the national reference collections of Philippine flora and fauna, rocks and minerals through research and field collection of specimens including Important Cultural Property within the territorial jurisdiction of the Philippines. It shall be exempt from any and all permit systems regulating the same.

(a) The exemption shall be guided with the following principles:

1. Natural History specimens are organisms and objects (live or preserved) that are collected or studied in the Philippines. This can include collections that are donated or given as exchange that can promote and develop the nation's rich natural and cultural heritage of the Filipino People;
2. The National Museum shall be exempt from applying for permits pertinent to collection and transport within the Philippines. Such research / collection activities shall be accompanied by a Travel Order an Authority to Collect duly signed by the Director of the National Museum or his duly authorized representative.
3. Collection, either of whole specimens or derivatives (such as parts, tissue samples, or genetic samples), shall be allowed only for the establishment of reference collection and / or taxonomic study.
4. The National Museum shall inform the Department of Environment and Natural Resources and the National Commission on Indigenous People for the collection of terrestrial species. It shall inform the Department of Agriculture for the collection of aquatic/marine species.
5. The local officials from the barangays to municipal and or city government officers shall also be informed of the collection. The Palawan Council for Sustainable Development (PCSD) shall be likewise be notified in case the collections is conducted in Palawan.
6. All holotype specimens of fossils, plants and animals collected in Philippine territory shall be deposited in the National Museum. However, all other types of specimens such as paratypes, neotypes, etc. need not necessarily be deposited at the National Museum chiefly for safety and security reasons.
7. All government agencies as well as private entities involved in research in natural history shall submit the list of holotypes with their corresponding information to the National Museum one hundred and twenty (120) days after the approval of these Rules. The transfer of holotypes shall be done upon request by the National Museum.
8. All holotypes of fossils, plants and animals are classified as Important Cultural Property while specimens belonging to endangered species; and irreplaceable specimens such as fossils, and specimens that are 100

years old or more are classified as Cultural Property Grade II. Holotypes may be declared National Cultural Treasures.

9. The Permit to Export any specimens under the category of cultural property shall be issued by the National Museum. Likewise, the National Museum shall issue the Certificate of Non-Coverage for all other natural history specimens.

10. Natural history specimens collected in the Philippines by the National Museum acquired through exchange and collaborative work, donation, gift and purchase shall be deposited in the National Museum.

(b) Natural History specimens can be accessed by the public following the rules and regulations on the access to museum collections and date.

(c) To establish linkages with researchers and scientists from local and foreign institutions, the National Museum shall designate them as National Museum Research Associates in conformity with its own guidelines.

Section 21. Heritage Agreements. – The Commission, upon advice of the concerned cultural agency, may enter into agreements with private owners of cultural properties with regard to the preservation of said properties.

Such agreement shall be in the form of a contract, and may include such terms and conditions including, but not limited to:

- (a) Public access to the property;
- (b) Value of the encumbrance;
- (c) Duration of the servitude of the property;
- (d) Restriction of the right of the owner or occupant to perform acts on or near the place;
- (e) Maintenance and management of the property;
- (f) Provision of financial assistance for the conservation of the property;
- (g) Provision of financial assistance for the conservation of the property; and,
- (h) Procedure for the resolution of any dispute arising out of the agreement.

Such agreement should be annotated in the land title to bind future owners and/or occupants of the immovable cultural property.

Section 22. National Inventory of Intangible Cultural Heritage. – The appropriate cultural agency shall closely collaborate with the UNESCO National Commission of the Philippines in the implementation of the provisions of the UNESCO conventions to which the Philippines is a signatory. The Philippine Intangible Cultural Heritage Committee established by the UNESCO National Commission of the Philippines shall continue to take lead role in implementing the provisions of the UNESCO Convention for the Safeguarding of the Intangible Cultural heritage with particular attention to Article 11 to 15 of the said Convention. This inventory shall be included in the registry.

Section 23. Immovable National Cultural Treasures. – Immovable National Cultural Treasures and important cultural properties or declared structures shall not be relocated, rebuilt, defaced or otherwise changed in a manner, which would destroy the property's dignity and authenticity, except to save such property from destruction due to natural causes.

The site referred to in this provision may only be moved after securing a permit from the Commission.

Section 24. Indigenous properties. – The appropriate cultural agency in consultation with the National Commission on Indigenous Peoples shall establish a program and promulgate regulations to assist indigenous people in preserving their particular cultural and historical properties.

Section 25. Renaming of Historical Streets, Buildings Designated as Cultural Treasure or Important Cultural Property. – The names of historical streets, parks, buildings, shrines, landmarks, monuments and sites designated as National Cultural Treasures or Important Cultural Property shall not be allowed to be re-named by a local or national legislation, unless approved by the National Historical Commission of the Philippines, and only after due hearing on the matter. Furthermore, for changes of names done to historical streets, parks, buildings, shrines, landmarks, monuments, and sites prior to the effectivity of this act, the National Historical Commission of the Philippines may direct the local government units to restore their original names, also after due hearing.

RULE VII REGULATING THE EXPORT, TRANSIT, IMPORT AND REPATRIATION OF CULTURAL PROPERTY

Section 26. Export of Cultural Property. – Whoever desires to export cultural property registered in the Philippine Registry of Cultural Property shall adhere to the following requirements:

- (a) Authorization from the Commission through the appropriate cultural agencies;
- (b) Application for export permit shall be submitted thirty (30) days before the intended export from the Philippines; and,
- (c) Application for export permit must include the following: (1) the purpose of the temporary export; (2) the export date of the cultural property; (3) the repatriation date of the cultural property; (4) a description of the cultural property; and, (5) the inventory of the cultural property in the Philippine Registry of Cultural Property.

The grant of export permit shall be based on the following conditions: (i) the cultural property is exported on a temporary basis; and, (ii) export of cultural property is necessary for scientific scrutiny or exhibit.

Section 27. Repatriation Claims and Agreements. – Should the cultural property registered in the Philippine Registry of Cultural Property be illicitly exported from the country, the Department of Foreign Affairs shall, upon the recommendation of the appropriate cultural agency, claim the right of repatriation vis-à-vis all other contracting States. Any compensation and costs shall be carried by the Philippine government subject to reimbursement and liability by the person who caused the illegal importation.

Section 27.1. International agreements. – For the protection of cultural and foreign affairs interests and to secure cultural heritage, the Philippines may conclude international treaties with contracting States on the import and repatriation of cultural property subject to the following conditions:

- (a) The scope of the agreement must be cultural property of significant importance to the cultural heritage of the contracting States;
- (b) The cultural property must be subject to the existing export policies for the purpose of protecting cultural heritage;
- and,
- (c) The contracting States shall grant reciprocal rights.

RULE VIII POWERS OF THE COMMISSION/CULTURAL AGENCIES

Section 28. Power to Issue a Cease and Desist Order. – When the physical integrity of the national cultural treasures or important cultural properties are found to be in danger of destruction or significant alteration from its original state, the appropriate cultural agency, shall immediately issue a Cease and Desist Order suspending all activities that will affect the cultural property. The local government unit, which has the jurisdiction over the site where the immovable cultural property is located, shall report the same to the appropriate cultural agency immediately upon discovery and shall promptly adopt measures to secure the integrity of such immovable cultural property. Thereafter, the appropriate cultural agency shall give notice to the owner or occupant of the cultural property and conduct hearing on the propriety of the issuance of the Cease and Desist Order. The suspension of the activities shall be lifted only upon the written authority of the appropriate cultural agency after due notice and hearing involving interested parties and stakeholders.

Section 29. Power to Issue Compulsory Repair Order. – When a privately- owned heritage site cannot be maintained by the owner or has fallen into disrepair thru neglect to such and extent that it will lose its potential for conservation, the Commission, through the appropriate cultural agency, may serve on the owner or occupant of such property, an order to repair or maintain such site. If the owner fails to comply with said order within thirty (30) to forty- five (45) days, repairs may be undertaken by the appropriate cultural agency for the account of the owner.

Section 30. Visitorial Powers. – The cultural agencies concerned, through the Commission, are hereby given the power to inspect National Cultural Treasures and Important Cultural Properties, and national historical landmarks, sites or monuments at any time to ensure the protection and integrity of such. They may also inspect public or private collections or objects that may be categorized as cultural property; Provided, That in the case of private collections or objects, the prior written consent of the owner shall be obtained.

Section 30.1. Coordination by the Commission. – The Commission shall coordinate the conduct of inspection by experts from the National Museum and/or the National Historical Commission of the Philippines on buildings and built environment declared as National Cultural Treasures and Important Cultural Properties and shall be responsible for deputizing law enforcement agents if necessary to enforce the visitorial power. Such inspections may be made in consonance with the required periodic monitoring of the such sites to determine their current condition, to address concerns of stakeholders on the property or to determine if the property is in danger or has actually been altered, demolished, or suffers neglect or deterioration.

Section 30.2. World heritage Sites. – The periodic monitoring of World Heritage Sites shall be in accordance with the recommended operational guidelines set by the UNESCO. The periodic monitoring shall be undertaken by the Commission using experts from the National Museum or National Historical Commission of the Philippines or members of the appropriate National Committee.

Section 30.3. Intangible cultural properties. – The Commission shall periodically monitor on site intangible cultural property and may therefore enter into communities to fulfill that purpose, subject to jurisdiction of government agencies such as National Museum and National Commission for Indigenous Peoples.

Section 31. Power to Deputize Other Government Agencies. – The cultural agencies concerned, as well as the Commission, shall have the power to deputize the Philippine National Police, the National Bureau of Investigation, the Armed Forces of the Philippines, the Philippine Coast Guard, and other local or national law enforcement agencies, including the Bureau of Fisheries' agents, the Department of the Environment and Natural Resources' rangers, the Bureau of Customs and Immigrations agents, members of the Office of the Special Envoy on Transnational Crimes and other such agencies and their successors in interest, to enforce the provisions of this Act and its implementing rules and regulations. The said agencies shall immediately detail their respective personnel to protect the cultural items under the National registry.

Failure to follow deputization order of the concerned cultural agency as well as the Commission shall be penalized in accordance with the provision of the act.

Section 31.1. Other instances of deputization. – The Commission at the request of the National Museum, shall coordinate the deputization of the Philippine National Police or the Armed Forces of the Philippines in relation to the protection of known or newly discovered archeological sites.

Section 32. Power to Recover Cultural Properties. – The Commission is empowered to recover or retrieve cultural properties which are under the custody of foreign nationals or entities and to bring these properties back to Philippine custody.

Section 33. Anthropological Research and Archaeological Exploration / Excavation. –

Section 33.1. Regulation and control of foreign and local research, data and specimen gathering, archeological exploration and excavation, treasure hunting and accidental discoveries. – The National Museum with respect to cultural/ archaeological/ anthropological matters, and the National Historical Commission of the Philippines, with respect to historical matters, shall regulate and control all anthropological research conducted by foreigners; and all archaeological excavation or exploration. Pursuant to the foregoing, the National Museums and/or the NHCP shall deputize other agencies to protect archaeological and anthropological sites. It shall be guided by the following rules:

1. All cultural property found in terrestrial and / or underwater archaeological sites belong to the State.
2. No terrestrial and/or underwater archaeological explorations and excavations for the purposes of obtaining materials and data of cultural value shall be undertaken without written authority and direct site supervision by archaeologists and/or representatives of the National Museum;
3. All anthropological researches, for the purpose of obtaining materials and data of cultural value and where the principal proponent is a foreign national shall be undertaken only with the authority and supervision of the National Museum or the National Historical Commission of the Philippines. Anthropological research by Philippine nationals, especially members of the indigenous communities shall be encouraged;
4. All surveys, exploration and excavation or diggings of archaeological or historical sites, whether in government or private property for the purpose of obtaining materials of cultural and historical value shall be undertaken only by the National Museum or any other institutions authorized by National Museum; Provided however, the archaeological project of any institution shall be subject to Permit System being imposed by the National Museum and shall be subject to inspection and monitoring at any time by an authorized representative of National Museum.
5. The National Museum is the sole institution that issues Permit to Conduct Archaeological Exploration and Excavation and shall continue the issuance of such permits pursuant to existing guidelines of the agency.
6. The National Museum shall formulate mechanisms in the granting of permit to conduct anthropological researches by foreign national. Only foreign anthropologists with a valid researcher's visit (visa) shall be allowed to conduct anthropological studies.
7. Special Authority to conduct anthropological researches shall be granted to foreigners who are designated as National Museum Research Associates.
8. All local anthropologists shall inform the National Museum Pertinent to their research in declared anthropological reservations.
9. Archaeological or anthropological materials presumed as important cultural property shall be allowed to leave the country only upon proper evaluation and written permission of the National Museum or the National Historical Commission of the Philippines;
10. All explorations and excavations undertaken wherein the caves, rock shelters and their vicinities may have been used in the prehistoric past by man either for habitation, religious and/or sacred and burial purposes all over the country, shall be under the direct jurisdiction and supervision of archaeologists and/ or other experts of the National Museum; The National Museum shall be responsible in the management and protection of caves assessed with cultural, paleontological and archaeological values in collaboration with the Regional Cave Committee.
11. The National Museum and the National Historical Commission of the Philippines shall participate actively in the National Cave Committee and Regional Cave Committees throughout the country to ensure that caves with cultural and historical values and preserved and protected.
12. All mining activities inside caves, rock shelters and any such other areas shall require a written permit and clearance from the National Museum. An appropriate prior inspection by representatives of the National Museum, funded by the company applying for a mining right, shall be required to ensure that no archaeological materials are present and, possibly, destroyed;
13. Archaeological Impact Assessment must be incorporated as one of the prerequisite for the issuance of Environmental Clearance Certificates which should be undertaken ahead of time prior to the start of the construction project.
14. The Regional Cave Committees shall inform the National Museum on the proposed mining activity to be undertaken in caves; In coordination with the company that applied for mining right, the National Museum

shall conduct test excavation in caves, rockshelters or any other such areas to ensure that no archaeological material is present.

15. The report on test excavation shall be submitted by the National Museum to the Department of Environment and Natural Resources. When the area has no archaeological significance, the National Museum shall issue a clearance which is a prerequisite requirement before the issuance of mining permit;

16. If the cave, rock shelter or similar areas yield archaeological and or historical objects, no clearance shall be issued and the site will be under the management of the National Museum and or National Historical Commission of the Philippines;

17. During the mining operation, the National Museum shall periodically dispatch personnel to assess the ongoing activities in caves, rock shelters and other similar areas;

18. All treasure hunting permits and licenses shall be issued by the National Museum, which shall formulate the rules and regulations to adequately control, regulate and monitor all applicants for such undertakings; and for this purpose, guidelines shall be adopted by the National Museum, as the lead agency in collaboration with the Department of Environment and Natural Resources through the Mines and Geo-Sciences Bureau which shall form part of these Rules;

19. The provisions of these Rules on explorations and excavations of terrestrial and underwater archaeological sites shall supersede all local, municipal, regional and autonomous regional governments' resolutions and ordinances.

20. The discoverer shall report the said cultural or historical property to the Commission or to the concerned agency; activities leading to the non-reporting of sites shall be considered physical interventions on archaeological or historical site and shall be penalized accordingly.

21. When the presence of any cultural or historical property is discovered, the National Museum or the National Historical Commission of the Philippines which may act through the Commission shall immediately suspend all activities that will affect the site and shall immediately notify the local government unit having jurisdiction of the place where the discovery was made. The local government unit shall promptly adopt measures to protect and safeguard the integrity of the cultural property so discovered and within five (5) days from the discovery shall report the same to the appropriate agency. The suspension of these activities shall be lifted only upon the written authority of the National Museum or the National Historical Commission of the Philippines and only after the systematic recovery of the archaeological materials. Such activities may include agricultural and engineering works, mineral and marine explorations;

22. All excavations in private property done by institutions other than concerned agency shall be undertaken only with the written consent of the owner(s) of the site and with the supervision of the qualified archaeologists or of such other persons who in the opinion of the concerned agency is competent to supervise the work;

23. All archaeological excavations done by other institutions shall be monitored by the representatives of the National Museum; The supervisor of an archaeological project shall be required by the concerned cultural agency to submit at any time a report on the progress of the project. The supervisor of an archaeological project shall, within 30 days upon the completion of the excavation or diggings, deposit with the concerned agency a catalogue of all the materials found thereon and description of archaeological context in accordance with the accepted archaeological practices.

24. After the analysis, all cultural and historical materials recovered from the excavations shall be turned over to the National Museum. Supported with a Memorandum of Agreement, authorized educational institutions or organizations may have a share of the collections provided that the objects shall be used for educational and research purposes. Only artifacts that are categorized as Cultural Property Grade III can be shared.

Section 33.2. Sharing of discovered materials. – Sharing of the collection as part of the deaccessioning policy of the National Museum or for a long term loan shall be subject to the pertinent guidelines of the National Museum.

Section 33.3. Fees. – All institutions authorized by the National Museum to explore, excavate, collect or conduct research, shall pay fees approved by the Director of the National Museum.

Section 33.4. Incentives. – The commission, upon the recommendation of the National Museum, shall

provide incentives for persons who discover and report heretofore unknown archaeological sites, in accordance with these Rules.

Section 33.5. Environmental Impact Assessment. – Any government or non-government infrastructure project or architectural site development shall include anthropological, archaeological, historical and heritage site conservation concerns in their Environmental Impact Assessment System.

Prior to the issuance of Environmental Clearance Certificate, Archaeological Impact Assessment is a requirement in areas declared as Heritage Zones and in known or newly discovered archeological sites. In the event that an archeological site is discovered on a project which had received a clearance, all earth moving activities shall cease immediately, subject to an assessment by the National Museum.

Section 33.6. National Museum shall establish guidelines for the verification and inspection of land and underwater archaeological sites which shall form part of these Rules.

RULE IX ROLE OF CULTURAL AGENCIES

Section 34. Responsibilities of Cultural Agencies for Designation of Cultural Property. – The cultural agencies, in conformity with their respective charters, shall define and delineate their respective areas of responsibility with respect to cultural property. These areas shall be subject to periodic reassessment whenever necessary.

Section 34.1. The Commission as administrator of RA 10066. – The commission will administer and execute the provisions of this Act not otherwise assigned to particular cultural agencies and any and all acts to be referred or delegated by the cultural agencies.

Section 34.2. The Cultural Agencies. – For purposes of this Act, the following shall be the responsibilities of cultural agencies in the categorization of cultural property:

- (a) The **Cultural Center of the Philippines (CCP)** shall be responsible for significant cultural property pertaining to the performing arts;
- (b) The **National Archives of the Philippines (NAP)** shall be responsible for significant archival records and materials;
- (c) The **National Library of the Philippines (NLP)** shall be responsible for rare and significant contemporary books, manuscripts such as, but not limited to, presidential papers, periodicals, newspapers, singly or in collection, and libraries and electronic records;
- (d) The **National Historical Commission of the Philippines (NHCP)** shall be responsible for significant movable and immovable cultural property that pertains to Philippine history; heroes and the conservation of historical artifacts;
- (e) The **National Museum (NM)** shall be responsible for significant movable and immovable cultural and natural property pertaining to collections of fine arts, architectural arts and built heritage, archaeology, anthropology, botany, geology, zoology and astronomy, including its conservation aspect;
- (f) The **Komisyon sa Wikang Filipino (KWF)** shall be responsible for the dissemination, development, and the promotion of the Filipino national language and the conservation of vernacular languages.

Section 35. Institutional Linkages of the National Cultural Agencies. – The cultural agencies and other national government agencies, as listed below, shall consult, coordinate and work closely with the Commission in the implementation of their respective programs/projects in the context of this Act. Furthermore, the Commission may link up with other agencies and institutions, as it may deem appropriate, as a way of dealing with conservation on a holistic manner.

- (a) The **Department of Tourism**, and its attached agencies, which shall be responsible for cultural education among tourism services, and protection of cultural property supplemental to the jurisdiction of the cultural agencies as defined in this Act. The implementation and creation of a tourism master plan shall be consistent with this Act;

- (b) The **Intramuros Administration** which shall be responsible for the restoration and administration of the development in Intramuros;
- (c) The **National Parks Development Committee** as an attached agency of the Department of Tourism, which shall be responsible in supervising the development (beautification, preservation and maintenance) of Quezon Memorial, Fort Santiago, Luneta, Paco Park, Pook ni Maria Makiling and other national parks and satellite projects;
- (d) The **Department of Education** which shall be responsible in instituting the governance of basic education act, and the conservation and restoration of its built heritage such as the significant Gabaldon School buildings as determined by the National Historical Commission of the Philippines;
- (e) The **Department of Public Works and Highways** which shall be responsible in undertaking major infrastructure projects specifically in the planning, design, construction, and maintenance of national roads and bridges as they impact on heritage structures or aspects of heritage conservation;
- (f) The **National Commission on Indigenous Peoples** in behalf of the country's indigenous cultural communities, which shall coordinate with the national agencies on matters pertaining to Cultural Property under its jurisdiction;
- (g) The **Department of Environment and Natural Resources** which shall be responsible for the establishment and management of the National Integrated Protected Areas System and the conservation of wildlife resources, including cave and cave resources and which shall coordinate with the National Commission on Indigenous peoples, the conservation of natural resources that are cultural sanctuaries of indigenous peoples;
- (h) The **Department of the Interior and Local Government** which shall coordinate with the national cultural agencies on matters pertaining to Cultural Properties under its jurisdiction, and ensure that the provisions of this Act is properly executed by the local government unit;
- (i) The **Office of the Muslim Affairs** which shall coordinate with the national cultural agencies on matters pertaining to Cultural Property under its jurisdiction;
- (j) The **UNESCO National Commission of the Philippines** which shall be responsible for providing the liaison between the cultural agencies of the Philippines and UNESCO as well as assist the national cultural agencies in implementing the agreements and conventions adopted by the UNESCO of which the Philippines has ratified or is in the process of ratification;
- (k) The **Housing and Land Use Regulatory Board** which shall coordinate with the local government units and the Commission on matters pertaining to the establishment and maintenance of Heritage Zones;
- (l) The **Autonomous Regional Government in Muslim Mindanao** and the **Cordillera Administrative Region** which shall coordinate with the national cultural Agencies on matters pertaining to Cultural Property under their respective jurisdictions; and,
- (m) The **Office of the Special Envoy on Transnational Crimes**, which shall have the oversight and operational capacity to go after illicitly trafficked and stolen cultural treasures.

Section 36. Incorporation of Cultural Property Programs in Local Government Units Budgets. – The local government units are encouraged to incorporate programs and budgets for the conservation and preservation of Cultural Property in their environmental, educational and cultural activities. The Commission may provide expert advice in the conduct of the local government's cultural activities.

Section 37. Training Programs. – The Commission, in coordination with the appropriate cultural agencies shall provide general training programs on conservation to the local government units which have established cultural heritage programs and projects in their localities.

RULE X CULTURAL PROPERTY INCENTIVES PROGRAM

Section 38. Tax Exemption on Donations. – All donations in any form to the Commission and its affiliated cultural agencies shall be exempt from the donor's tax and the same shall be considered as allowable deduction from the gross income in the computation of the income tax of the donor, in accordance with the provisions of the National Internal Revenue Code of 1997, as amended, subject to the issuance of the appropriate rules thereon by the Bureau of Internal Revenue.

Section 39. National Heritage Resource Assistance Program. – The Commission may provide financial assistance in the form of a grant to historic, archaeological, architectural, artistic organizations for conservation or research on cultural property. No grant made pursuant to this Act shall be treated as taxable income.

Section 40. Awards and Citations. – To encourage preservation of the national heritage, the Commission shall establish an annual conservation recognition program under which monetary prizes, awards and citations will be given by the President of the Philippines, upon the recommendation of the Commission, for special achievements and important contributions and services in the area of heritage preservation and conservation efforts.

(a) The Annual Heritage Conservation Recognition Program shall be staged during the annual Heritage Month Celebrations to honor outstanding achievements in the field of heritage preservation and conservation.

(b) In its first year of implementation, the Annual Heritage Conservation Recognition Program shall cover feats and accomplishments within the two immediately preceding years of living individuals and existing organizations.

(c) The Commission shall adopt applicable parameters of the NCCA Gawad Alab ng Haraya including General Nomination Rules and Requirements, and Criteria for Selection.

(d) Subject to the Commission's discretion and determination, winners of the Annual Heritage Conservation Recognition Program Awards shall be accorded citations and monetary prizes.

RULE XI CULTURAL EDUCATION

Section 41. Incorporation of National Cultural Treasures and Important Cultural Properties in the Basic Education System. – Within one (1) year from the effectivity of this Act, the Department of Education in coordination with the Commission's Philippine Cultural Education Program shall formulate the cultural heritage education programs both for local and overseas Filipinos to be incorporated into the formal, alternative and informal education, with emphasis on the protection, conservation and preservation of cultural heritage property.

The Philippine Registry of Cultural Property shall likewise be incorporated into the formal, alternative, and informal education by the provincial and local governments.

Section 42. Cultural Heritage Education Program. – Within one (1) year from the effectivity of this Act, the Department of Education, the Technical Education and Skills Development Authority and the Commission on higher Education in consultation with the Commission shall set forth in its teaching programs nationwide the following cultural heritage education programs with emphasis at the provincial, city and municipal levels:

(a) Protection, conservation and preservation of cultural heritage properties;

(b) Instructional materials in print, film and broadcast media on the cultural and historical significance of cultural properties; and,

(c) Visitation, public accessibility and information dissemination on designated local cultural properties.

Section 43. Public Accessibility. – Access to national historical landmarks, monuments and sites, whether designated as National Cultural Treasure, Important Cultural Property by the general public for visitation and information, and by government representatives for inspection, shall not be hindered except on reasonable cause. Fees, as prescribed by the cultural agency concerned, may in appropriate cases be charged to defray cost of conservation, inclusive of general maintenance and upkeep. In the case of privately owned monuments and sites, the National Historical Commission of the Philippines or the National Museum shall arrange with the owners the schedules of visits and regular inspection.

Specimens shall be available for study by bona fide students, researchers and other interested persons under the supervision of authorized staff and following policies on the access to collection and data of concerned agency.

Published research data and relevant information shall be shared with the public.

Entrance fees shall be charged in National Museum's archaeological sites and branch museums.

RULE XII CULTURAL HERITAGE WORKERS' INCENTIVES PROGRAM

Section 44. Cultural Heritage Workers' Incentives. – The national cultural agencies, in coordination with the Commission on Higher Education shall initiate scholarships, educational training programs, and other measures to protect the well-being of curators, conservators, authenticators and valuers/appraisers of cultural property. Such cultural workers shall be given grants, incentives and scholarships upon the endorsement by the head of the appropriate cultural agency.

(a) **Program for Cultural Heritage Workers.** Within ninety (90) days from the effectivity of this Act, the Commission through the cultural agencies concerned shall come up with the following:

- 1) An active Roster of Authenticators and Valuers/Appraisers;
- 2) An education and training plan for conservators, authenticators, valuers / appraisers, and other conservation related workers; and,
- 3) A general training plan on conservation for local government units.

(b) **Application of Scientific Career Merit System.** Cultural heritage workers in the Civil Service with a Doctorate, Master of Science, or Master of Arts Degree in fields related to cultural heritage promotion and conservation, shall be given the rank and benefits of Scientists, subject to qualifying standards equivalent to those prescribed in the scientific career merit system of the government.

A cultural heritage worker involved in science and technology in the government agencies shall be eligible for the benefits under Republic Act 8439 or the Magna Carta for Scientists, Engineers, Researchers and other S&T Personnel in Government. The Commission shall likewise establish a merit award system for non-civil service cultural heritage workers.

RULE XII SENTRO RIZAL

Section 45. Purpose and General Coverage. – These Implementing Rules and Regulations for the Sentro Rizal are promulgated pursuant to Sections 38, 42, 43, 44, 45, 46, 47 and 51 of Republic Act 10066. It shall cover the functions of the Sentro Rizal, the participation of various government agencies and appropriations.

Section 46. Statement of Policy. – It is the policy of the State to promote, and popularize the nation's historical and cultural heritage and resources, as well as artistic creations and to ensure equal access to cultural opportunities through the educational system, public or private cultural entities and community cultural centers, and other public venues. (Art. XIV, Secs. 15 and 18, 1987 Constitution)

Section 47. Construction. – The Implementing Rules and Regulations for the Sentro Rizal shall be liberally construed in order to carry the national policy of promoting Philippine culture particularly among overseas Filipinos.

Section 48. Sentro Rizal. – The National Commission for Culture and the Arts shall establish the Sentro Rizal to be located in its main office.

Section 49. Offices and Branches. – Thereafter the NCCA shall establish offices or branches of the Sentro Rizal in countries where there are children of overseas Filipino workers who need to be educated about their roots, as well as in developed countries where there are large Filipino communities.

Section 50. Overseas Locations. – The overseas offices or branches of the Sentro Rizal are to be located as follows:

- (a) In countries where there are children of overseas Filipino workers who need to be educated about their roots, the office or branch shall be located in the Philippine embassy or consulate nearest the areas where most of the families of said children are located.

(b) In developed countries where there are large Filipino communities, the Sentro Rizal may be located in privately owned buildings or offices and may be run by local Filipino expatriates or former Filipino citizens.

Section 51. Functions of the Sentro Rizal offices or branches. – The Sentro Rizal office or branch shall, among others, have the following functions:

(a) Be repositories, inter alia, of the following materials on Philippine art, culture and language: books, digital video discs, compact discs, films, magazines, artworks, tourism promotion materials, information materials. All these shall be made available to the public both Filipino and foreign.

(b) Organize cultural events and activities for Filipinos, especially for children overseas, hold fora on indigenous traditions and practices along with cultural heritage campaigns for Philippine heritage promotions abroad. The branches and offices shall duly report these activities to the Sentro Rizal on a quarterly basis.

(c) Coordinate the activities of visiting artists and performing groups from the Philippines to ensure maximum participation and community impact.

(d) Offer Filipino language courses, their study and appreciation thereof, for children and adults, as well as exhibits, small concerts, poetry reading and Philippine cuisine lessons.

Section 52. Participation of Government Agencies. – The pertinent government agencies shall have the following participations:

(a) The Department of Tourism as well as the Department of Education, National Commission for Culture and the Arts, Commission for Higher Education, the National Historical Commission of the Philippines, National Museum of the Philippines, National Archives of the Philippines, the National Library of the Philippines, the Komisyon ng Wikang Filipino, and the Cultural Center of the Philippines shall provide information materials to the Sentro Rizal branches overseas.

(b) In the same manner the Department of Trade and Industry will also provide trade and investment materials.

(c) The Department of Education, in coordination with the Commission's Philippine Cultural Education Program shall formulate the cultural heritage education programs for overseas Filipinos to be incorporated into the formal, alternative and informal education, with emphasis on the protection, conservation and preservation of cultural heritage property.

(d) The Commission for Filipinos Overseas (CFO) shall work as the partner agency for the NCCA and may assist the latter in establishing or operating or may itself operate Sentro Rizal in any of the schools falling under its oversight functions.

Section 53. The Sentro Rizal Secretariat. – The Sentro Rizal shall be under the office of the NCCA Chairman who shall set its staffing and with due consultation with the NCCA Board, set its yearly budget.

Section 54. Separability Clause. – If any clause, sentence, section or provision of these rules is held or declared unconstitutional, or invalid by a competent court, the remaining parts of these Implementing Rules and Regulations shall not be affected thereby.

Section 55. Repealing and Amending Clause. – All Rules and Regulations and resolutions of the NCCA Board inconsistent with or contrary to the provisions of these Implementing Rules and Regulations, are hereby repealed or modified accordingly.

Section 56. Effectivity. – These rules and regulations shall take effect immediately after publication in two newspapers of general circulation or in the Official Gazette, whichever takes place sooner. A copy of these Rules shall be deposited in the National Administrative Register.

S. No. 3472
H. No. 6378

Republic of the Philippines
Congress of the Philippines
Metro Manila
Fourteenth Congress
Third Regular Session

Begun and held in Metro Manila, on Monday, the twenty-seventh day of July, two thousand nine.

[REPUBLIC ACT NO. 10086]

AN ACT STRENGTHENING PEOPLES' NATIONALISM THROUGH PHILIPPINE HISTORY BY CHANGING THE NOMENCLATURE OF THE NATIONAL HISTORICAL INSTITUTE INTO THE NATIONAL HISTORICAL COMMISSION OF THE PHILIPPINES STRENGTHENING ITS POWERS AND FUNCTIONS, AND FOR OTHER PURPOSES

Be it enacted by the Senate and House of Representatives of the Philippines in Congress assembled:

SECTION 1 Short Title. – This Act shall be known as the “Strengthening Peoples’ Nationalism Through Philippine History Act”.

SEC. 2. Declaration of Policy. – It is hereby declared to be the policy of the State to conserve, promote and popularize the nation’s historical and cultural heritage and resources. Pursuant to the Constitution, all the country’s artistic and historic wealth constitutes the cultural treasure of the nation and shall be under the protection of the State which may regulate its disposition.

Towards this end, the State shall provide the means to strengthen people’s nationalism, love of country, respect for its heroes and pride for the people’s accomplishments by reinforcing the importance of Philippine national and local history in daily life with the end in view of raising social consciousness; reinvigorating government support for historical research; and sustaining and enhancing programs for the protection, preservation and conservation of historical relics and memorabilia, monuments, sites and other historical resources.

The State shall likewise give utmost priority not only to the research on history but also to the popularization of history. In this way, the State will be able to build a Philippine national identity based on unity and pride in diversity held together by a common history.

SEC. 3. Definition of Terms. – For purposes of this Act, the following terms shall be defined as follows:

- (a) “Built heritage” refers to architectural and engineering structures such as, but not limited to, bridges, government buildings, houses of ancestry and worship, traditional dwellings, technological and industrial complexes and their settings, and landscapes with notable historical and cultural significance.
- (b) “Classified” refers to structures and sites marked and listed as such and recorded in the National Historical Commission of the Philippines’s National Registry of Historic Sites and Structures, and not falling under any of the five (5) categories of historic sites and structures, namely: National Shrines, National Monuments, National Landmarks, Heritage Houses and Historic Sites.
- (c) “Conservation” refers to all processes and measures of maintaining the cultural significance of a cultural property including, but not limited to, physical, social or legal preservation, restoration, reconstruction, protection, adaptation or any combination thereof.

- (d) "Documentation" refers to the recording in a permanent format of information derived from research, conservation and other activities of the National Historical Commission of the Philippines (NHCP).
- (e) "Heritage houses" refers to houses of ancestry with notable historical, cultural, social, architectural and artistic value and significance as declared by the NHCP.
- (f) "Historic site" refers to a place recognized to have an important historical significance as declared by the NHCP.
- (g) "Historical street name" refers to a street name which has been in existence for at least fifty (50) years.
- (h) "History" refers to the record of people, places and events in the past; it can also mean the discipline involving the study of people, places and events in the past.
- (i) "History museum" refers to a place where relics and memorabilia and other resources pertaining to important people, places and events in the past are thematically presented and systematically preserved, catalogued or displayed for public appreciation and education.
- (j) "Historical research" refers to the scholarly investigation of people, places and events in the past.
- (k) "Historical writing" refers to the coherent, narrative and scholarly documentation of people, places and events in the past.
- (l) "National historical landmarks" refers to sites or structures which are associated with events or achievements significant to Philippine history declared as such by the NHCP.
- (m) "National historical monuments" refers to structures erected as a memorial to great heroes or events in Philippine history declared as such by the NHCP.
- (n) "National historical shrines" refers to sites or structures hallowed and revered for their history or association declared as such by the NHCP.
- (o) "National registry of historic sites and structures" refers to the records of all historic sites and structures of the country as found in the documentation of the NHCP.
- (p) "Philippine history" is the study of people, events and places from the dawn of the recorded past of the Philippines to contemporary period.
- (q) "Preservation" refers to all activities that employ means to control, minimize or prevent damage or deterioration to cultural property.
- (r) "Restoration" refers to the action taken or the technical intervention to correct deterioration and alterations and return cultural property to its original state or condition.

SEC. 4. Renaming of the National Historical Institute. – The nomenclature of the National Historical Institute (NHI), established pursuant to Presidential Decree No. 1, series of 1972, is hereby changed to National Historical Commission of the Philippines (NHCP).

The NHCP shall be an independent agency attached to the National Commission for Culture and the Arts (NCAA).

SEC. 5. General Mandate. – The NHCP is the primary government agency responsible for history and has the authority to determine all factual matters relating to official Philippine history.

In this regard, the NHCP shall:

- (a) conduct and support all kinds of research relating to Philippine national and local history;
- (b) develop educational materials in various media, implement historical educational activities for the popularization of Philippine history, and disseminate information regarding Philippine historical events, dates, places and personages;
- (c) undertake and prescribe the manner of restoration, conservation and protection of the country's historical movable and immovable objects;
- (d) manage, maintain and administer national shrines, monuments, historical sites, edifices and landmarks of significant historico-cultural value; and
- (e) actively engage in the settlement or resolution of controversies or issues relative to historical personages, places, dates and events.

SEC. 6. The Board. – The NHCP shall be governed by a nine (9)-member Board, which shall be created to formulate and implement NHCP policies relating to the agency’s mandate.

SEC. 7. Powers and Functions of the Board. – The Board of the NHCP shall exercise the following powers and functions:

- (a) Conduct and encourage all manner of research pertaining to Philippine national and local history;
- (b) Acquire important historical documents, collections, memorabilia and other objects that have significant historical value;
- (c) Acquire real property, buildings and other structures for the purpose of preserving, restoring and conserving their significant historical value;
- (d) Determine the manner of identification, maintenance, restoration, conservation and preservation of historical sites, shrines, structures and monuments;
- (e) Approve the declaration of historic structures and edifices such as national shrines, monuments and landmarks or heritage houses;
- (f) Prescribe the manner of celebration or commemoration of significant events pertaining to Philippine history;
- (g) Initiate and, in cooperation with the appropriate government or private entity, promote programs for the popularization of Philippine history such as, but not limited to, the integration of the subject of history into the school curriculum, among others;
- (h) Discuss and resolve, with finality, issues or conflicts on Philippine history;
- (i) Implement and enforce Republic Act No. 8491, otherwise known as the Flag Law, and other special laws where the NHCP has been designated as the implementing body;
- (j) Secure and receive local, bilateral and international donations, grants and endowments in support of its programs and projects;
- (k) Develop and implement consortium agreements to link other government agencies and/or private individuals and organizations engaged in or in support of the mandate of the NHCP;
- (l) Regulate activities pertaining to the preservation, restoration and conservation of historical property or resources;
- (m) Generate funds from government or private sources, local or international for its programs and projects;
- (n) Collect reasonable fees for the use, sale or rent of its resources as well as entrance fees to shrines and landmarks under the jurisdiction of the NHCP;
- (o) Approve grants, create committees or deputize individuals for NHCP projects;
- (p) Conduct public hearings and ocular inspections or initiate factual investigations with respect to disputed historical issues for the purpose of declaring official historical dates, places, personages and events;
- (q) Approve the annual budget of the NHCP before its presentation to the Department of Budget and Management (DBM) and Congress;
- (r) Appoint the Deputy Executive Directors of the NHCP; and
- (s) Exercise oversight functions over the administrative operations of the NHCP.

SEC. 8. Composition of the Board. – The Board shall be headed by a Chairperson and shall be composed of five (5) distinguished historians representing the private sector who shall serve as regular members of the Board and who shall be appointed by the President of the Republic of the Philippines. Only the regular members can vote on matters relating to historical research and similar academic concerns. The following shall serve as ex officio members:

- (a) The Director of the National Library of the Philippines;
- (b) The Director of the National Museum;
- (c) The Executive Director of the National Archives of the Philippines; and
- (d) The Executive Director of the NHCP.

SEC. 9. Qualifications of Regular Members of the Board. – No person shall be appointed or elected to the Board unless he/she possesses the following minimum qualifications:

- (a) A natural-born citizen of the Republic of the Philippines;
- (b) At least thirty-five (35) years of age;
- (c) With good moral character;
- (d) Has distinguished himself/herself in the field of Philippine history; and
- (e) Has published works in Philippine history and other academic fields recognized by scholars and the reading public.

SEC. 10. Regular Members; Term of Office. – The regular members of the Board shall serve for a term of four (4) years: Provided, That the first five (5) appointees pursuant to this law shall hold office under the following staggered terms, namely: two (2) appointees will have a full term of four (4) years; two (2) appointees will have a term of three (3) years; and the remaining appointee shall have a term of two (2) years: Provided, further, That the regular members shall not serve for more than two (2) consecutive terms. Appointment to any vacancy shall only be for the unexpired portion of the term of the predecessor. In no case shall a member be appointed or designated in a temporary or acting capacity.

SEC. 11. Election of the Chairman. – The Board shall be headed by a Chairman who shall be elected from among the regular members in an election to be participated in by all the members of the Board.

SEC. 12. Term of Office of the Chairman. – The Chairman shall have a term of three (3) years and shall not serve more than two (2) consecutive terms.

SEC. 13. Functions of the Chairman. – The Chairman is the head of the agency and shall represent and act for the Board in all matters pertaining to the NHCP. The Chairman, being the public face of the NHCP, shall:

- (a) provide leadership in the realization of the vision and mission of the NHCP;
- (b) advise the President and Congress on matters relating to Philippine history;
- (c) preside over meetings of the Board;
- (d) propose the agenda for meetings of the Board;
- (e) exercise oversight over the Executive Director and Deputy Executive Directors to ensure the implementation of policies, decisions and resolutions of the Board;
- (f) represent the NHCP on official matters;
- (g) represent the NHCP in the Board of the NCCA and other agencies where the NHCP head of agency sits; and
- (h) perform such other authority, functions or duties which the President of the Philippines or the Board may delegate.

SEC. 14. The Executive Director. – The Executive Director shall be appointed by the President of the Republic of the Philippines. He/She shall have a rank equivalent to a bureau director.

SEC. 15. Functions of the Executive Director. – The Executive Director shall have the following functions:

- (a) Implement the policies and programs approved and promulgated by the NHCP Board;
- (b) Administer the day-to-day operations of the NHCP;
- (c) Represent the NHCP in meetings when authorized or delegated by the Board; and
- (d) Perform such other functions assigned by the NHCP Board.

SEC. 16. The Deputy Executive Directors. – The Executive Director shall be assisted by a Deputy Executive Director for Administration and a Deputy Executive Director for Programs and Projects.

The Deputy Executive Directors shall be appointed by the Board.

SEC. 17. Qualifications of the Executive Director and Deputy Executive Directors. – No person shall be appointed or designated as Executive Director and Deputy Executive Directors of the NHCP unless he/she possesses the following minimum qualifications:

- (a) A natural-born citizen of the Republic of the Philippines;
- (b) Has good moral character;
- (c) Holder of any four (4)-year college degree;
- (d) Has at least five (5) years of actual and relevant experience in managing a government agency in the case of the Executive Director and three (3) years experience in the case of the Deputy Executive Directors; and
- (e) Has career executive service officer (CESO) eligibility only with respect to the Deputy Executive Director position.

SEC. 18. Delegation of Authority. – The Executive Director shall have authority over and responsibility for the day-to-day operations of the NHCP. He/She may delegate such authority to the Deputy Executive Directors to implement plans and programs. The delegation shall be in writing; shall indicate the name of specific officer to which the delegation is made; shall indicate the duties and responsibilities delegated; shall indicate the length of period of delegated authority; and shall vest sufficient authority to enable the delegate to discharge his/her assigned responsibility.

SEC. 19. Reorganization. – Within one hundred twenty (120) days from the effectivity of this Act, the Board shall have the authority to reorganize the structure of the NHI, including its staffing pattern in order to carry out its functions pursuant to its expanded mandate as the NHCP.

Employees of the NHI shall be subsumed in the NHCP and, whenever qualified, be upgraded to their analogous positions. Employees opting to avail of an early retirement scheme shall be granted under the existing DBM guidelines.

SEC. 20. Historic Sites and Structures Documentation Center. – A Historic Sites and Structures Documentation Center (HSSDC) shall be established within the NHCP, replacing the existing Survey and Documentation Section, which shall be tasked with undertaking the survey, identification, documentation and recommendation for declaration of historic structures and edifices such as national shrines, monuments and landmarks or heritage houses by the NHCP Board and maintaining the National Registry of Historic Sites and Structures.

SEC. 21. Local Historical Committees Network. – The existing work of the agency on historical society affiliations shall constitute the Local Historical Committees Network (LHCN). The LHCN shall monitor, coordinate, support and, upon approval of the Board, affiliate various local historical bodies engaged in the collection, documentation, popularization, conservation, restoration and preservation of extant historical materials found in different parts of the Philippines. It shall also record the oral histories of towns, cities, provinces, regions and peoples.

SEC. 22. Materials Research Conservation Division. – The Materials Research Conservation Center of the agency shall be renamed as Materials Research Conservation Division (MRCD). Aside from its regular functions, it shall provide consultancy services to collectors of historical objects that are considered valuable components of Filipino heritage to ensure that preservation, restoration and conservation techniques and procedures are in accordance with the accepted international standards set in protecting historical objects and materials. The MRCD shall enrich and update knowledge on restoration and preservation techniques through scientific research. It shall likewise establish linkages between the Philippines and various international bodies engaged in the scientific preservation of historical and cultural objects.

SEC. 23. Tax Exemption on Donations. – The provisions of any general or special law to the contrary notwithstanding:

- (a) The NHCP shall be exempt from all taxes on its income;
- (b) All donations in any form to the NHCP shall be exempt from the donor's tax and the same shall be considered as allowable deduction from the gross income in the computation of the income tax of the donor, in accordance with the provisions of Republic Act No. 8424, otherwise known as the National Internal Revenue Code of 1997, as amended; and
- (c) Importation of scientific, philosophical, historical and cultural books, supplies and materials for the use in the conservation or preservation work of the NHCP and duly certified by the Board, shall be exempt from customs duties.

SEC. 24. Revolving Fund. – The income of the NHCP not exceeding the amount of One million pesos (P1,000,000.00) derived from the proceeds of publications, park entrance fees and donations, the rendering of technical services, conferences and workshops and similar income shall be constituted as a revolving fund to augment the projects where the income was derived subject to government auditing rules and regulations: Provided, That proceeds in excess of the aforementioned amount shall be remitted to the National Treasury and accrue to the General Fund.

SEC. 25. Funding Provision. – The amount necessary for the effective implementation of this Act shall be included in the annual General Appropriations Act.

SEC. 26. Transitory Provisions. – The incumbent Chairman, Executive Director and Deputy Executive Directors of the NHI shall continue to serve in their respective capacities as the Chairman, Executive Director and Deputy Executive Directors of the herein established NHCP for one (1) year after the effectivity of this Act or until a new Chairman and Executive Director shall have been appointed by the President and the two (2) new Deputy Executive Directors shall have been appointed by the Board.

All assets, fixed and movable, and all contracts, records and documents relative to the operations of the NHI are hereby transferred to the NHCP.

All agreements and contracts entered into by the NHI shall remain in full force and effect unless otherwise terminated, modified or amended by the NHCP.

Officials and employees of the NHI shall be absorbed by the NHCP on the basis of merit and fitness: Provided, That officers and employees who shall be separated from the service as a result of the abolition of any of the divisions therein shall be entitled to retirement and other separation benefits provided under existing laws.

SEC. 27. Implementing Rules and Regulations. – The NHCP, in consultation with the other government agencies mentioned in this Act, shall promulgate the implementing rules and regulations within ninety (90) days after the effectivity of this Act.

SEC. 28. Separability Clause. – If any provision of this Act is held invalid or unconstitutional, the same shall not affect the validity and effectivity of the other provisions hereof.

SEC. 29. Repealing Clause. – The pertinent provisions of Presidential Decree No. 1, series of 1972 and all other laws, decrees, executive orders and rules and regulations contrary to or inconsistent with the provisions of this Act are hereby repealed or modified accordingly.

SEC. 30. Effectivity Clause. – The Act shall take effect fifteen (15) days after its publication in at least two (2) newspapers of general circulation.

Approved,

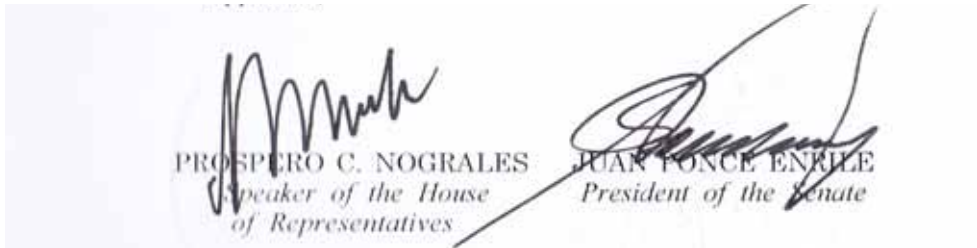

PROSPERO C. NOGRALES
*Speaker of the House
of Representatives*

JUAN PONCE ENRILE
President of the Senate

This Act which is a consolidation of Senate Bill No. 3472 and House Bill No. 6378 was finally passed by the Senate and the House of Representatives on January 26, 2010 and January 27, 2010, respectively.

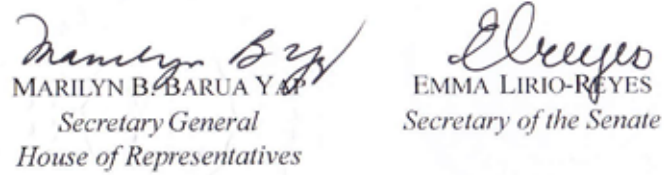

MARILYN B. BARUA YAP
*Secretary General
House of Representatives*

EMMA LIRIO-REYES
Secretary of the Senate

Approved:

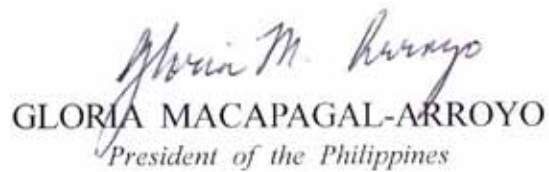



GLORIA MACAPAGAL-ARROYO
President of the Philippines

APPENDIX 2. List of Acquired Materials









The materials below are for your information. The materials are in order of publication year.

1. Materials purchased during the survey



Title	Author	ISBN	Year	Cover
A Sourcebook to the Museum of the Filipino People	Sandra Castro, 他	Unknown	2005	
La Casa de Dios, The Legacy of Filipino-Hispanic Churches in the Philippines	Fr. René B. Javellana, SJ	978-971-94919-0-3	2010	

2. Materials offered during the survey

Title	Author	ISBN	Year	Cover
National Museum Annual Report 1998	National Museum	Unknown	1998	
The Realm of ASEAN, One Region, One Culture	Office of ASEAN Affairs, Department of Foreign Affairs, Republic of the Philippines	Unknown	1998	
Shell Ornamentation of La Purísima Concepción, Parish Church, Guiuan, Eastern Samar	Ángel P. Bautista	971-814-039-5	2003	
Tubod: The Heart of Bohol	The National Commission for the Culture and the Arts	971-814-036-0	2003	
Pintacasi, The Journal on the Cultural Heritage of the Church. II	Catholic Bishops' Conference of the Philippines, University of Santo Tomas	Unknown	2006	
Pintacasi, The Journal on the Cultural Heritage of the Church. III	Catholic Bishops' Conference of the Philippines, University of Santo Tomas	Unknown	2007	
Balangkas, A Resource Book on the Care of Built Heritage in the Philippines	National Commission for Culture and the Arts, The Committee on Monuments and Sites	978-971-814-106-9	2007	
Kisame: Visions of Heaven on Earth	Ayala Museum	978-971-8551-57-8	2008	
Pintacasi, The Journal on the Cultural Heritage of the Church. IV	Catholic Bishops' Conference of the Philippines, University of Santo Tomas	Unknown	2008	

The Bohol Arts and Cultural Heritage Code, Provincial Ordinance No.2008-002	Republic of the Philippines, Province of Bohol, City of Tagbilaran	Unknown	2008	
Santa Ana Church of Manila, Parish of our Lady of the Abandoned, A Historical Guide	The Cofradía de la Inmaculada Concepción	Unknown	2008	
Pintacasi, The Journal on the Cultural Heritage of the Church. V	Catholic Bishops' Conference of the Philippines, University of Santo Tomas	Unknown	2009	
Towns and Cities of the Philippines, Selected Cases on the History and Evolution of Settlements	Heritage Conservation Society, Urban Partnerships Foundation	978-971-94768-1-8	2010	
Heritage Homeowner's Preservation Manual, World Heritage City of Vigan Philippines	UNESCO, City Government of Vigan	978-92-9223-319-8	2010	
Heritage Pilgrimage Guide Book	Filipino Heritage Festival	Unknown	2011	
A Pattern for Development	Japan International Cooperation Agency (JICA)	Unknown	2011	
The Tabon Cave Complex of Lipuun Point	National Commission for Culture and the Arts-Intangible Heritage Committee	978-971-814-182-3	2011	
Annual Report 2011	National Museum	Unknown	2011	
Vigan Conservation Code	Republic of the Philippines, Province of Ilocos Sur, City of Vigan	Unknown	2011	
San Agustin Church	Unknown	Unknown	Unknown	

3. Pamphlets obtained during the survey

Title	Publisher	Cover
Padayon Baclayon, Bahandi Heritage Walk	Bahandi, Baclayon Ancestral Houses for New Development Initiatives	
The Cathedral Museum of Cebu	Cebu Archdiocesan Commission for the Cultural Heritage of the Church	

Casa Manila, Intramuros	Department of Tourism	
Intramuros	Intramuros Administration	
The National Museum of the Philippines	National Museum of the Philippines	

4. Materials available in Japan

Title	Author	Publisher	ISBN	Year	Cover
Japanese					
暮らしがわかる アジア読本 フィリピン	(編) 宮本勝, 寺田勇文	河出書房新社	4-309-72443-4	1994	
フィリピンの文化と交易の時代 青柳洋治コレクションを中心に	(編) 横浜ユーラシア文化館	横浜ユーラシア文化館	978-4-902282-10-8	2011	
明石ライブラリー148 フィリピンと日本の戦後関係 歴史認識・文化交流・国際結婚	(編著) リディア・N.ニュー・ホセ (訳) 佐竹真明, 小川玲子, 堀芳枝	明石出版	978-4-7503-3506-3	2011	
エリア・スタディーズ11 現代フィリピンを知るための61章【第2版】	(編著) 大野拓司, 寺田勇文	明石出版	978-4-7503-3056-3	2012	
フィリピンのアートと国際文化交流	鈴木勉	水曜社	978-4-88065-284-9	2012	
English					
2000 Annual Report	National Commission for Culture and the Arts	NCCA Public Affairs and Information Division	Unknown	2000	
"A VOYAGE OF 100 YEARS" A Centennial Magazine of the National Museum	Lolita J. Bulalacao	Republic of the Philippines Office of the President THE NATIONAL MUSEUM	Unknown	2001	
LIVING LANDSCAPES AND CULTURAL LANDMARKS WORLD HERITAGE SITES IN THE PHILIPPINES	Augusto F. Villalón	ArtPostAsia Pte Ltd.	971-93170-3-5	2005	
Glimpses of Old Cebu Images of the Colonial Era	Lucy Urgello Miller	The University of San Carlos Press	978-971-539-020-0	2010	
CASA BOHOLANA VINTAGE HOUSE OF BOHOL	Erik Akpedonu, Czarina Saloma	Ateneo de Manila University Press	978-971-550-618-2	2011	